

# Hepworth



## WATERMAIN uPVC IMPERIAL / METRIC PRESSURE PIPE

PRODUCT & TECHNICAL GUIDE



# Hepworth

## CONTENTS

INTRODUCTION	1
BRITISH STANDARDS	2
PIPES	3 – 8
JOINTS & COUPLERS	9 – 10
FLOW DATA	11
FLOW CHART FOR UPVC PIPES	12
TRENCH WORK	13
BEDDING MATERIAL	14
PIPE LAYING AND JOINTING	15 – 21
TEMPERATURE CONVERSIONS	22
HYDROSTATIC TESTING	23
INSPECTION AND TESTING	24
PRESSURE EQUIVALENTS TABLE	25
MATERIAL PROPERTIES OF UPVC	26
CHEMICAL RESISTANCE TABLE	27 – 30
GENERAL GUIDANCE NOTES	31 – 32
HANDLING, TRANSPORT AND STORAGE	33 – 34

# WATERMAIN uPVC PRESSURE PIPE

Hepworth PME LLC, based in Dubai, has been manufacturing and marketing pipes, fittings and related products in the Middle East, for more than 40 years. Hepworth manufactures PVC Solid Wall and Multi layer, HDPE, PPR, PB, ABS pipes and fittings in the UAE, Oman and Qatar. Its subsidiary companies in Bahrain and Saudi Arabia and exports globally.

Hepworth represents and manufacture pipes and fittings under license for Wavin and Georg Fischer. Also distributes complementary products, including equipment and valves.

For more details, please visit:

[www.hepworth.ae](http://www.hepworth.ae)

# WATERMAIN uPVC PRESSURE PIPE

## BRITISH STANDARDS

A Kitemark on a product is an important symbol to you the purchaser; it means that the product has been manufactured and tested to the stringent requirements laid down by British Standards Institution, who by means of regular visits and independent testing, ensure that the products consistently meet these standards.

The Quality Systems operated by a manufacturer also has to confirm to the British Standard that



controls overall quality assurance (B.S. 5750 part 11 Quality Systems), and a Kitemark is not granted unless a manufacturer's Quality System has been assessed to this standard, and subsequently proven to comply with it.

The Kitemark scheme represents a commitment by a manufacturing company to ensure that its quality is of the highest standard.

## STANDARD BS EN 1452-2:2009 Kitemark formally BS 3505:1986

### A MAJOR STEP FORWARD

The new British Standard B.S. EN 1452-2 : 2009 is the major revision of the standard relating to the use of UPVC pressure pipes in potable water applications since 1968. It draws upon 25 years experience of plastic pipe manufacture and use in the UK and on the continent. It incorporates improved performance testing, bringing still greater confidence in the specification of UPVC renovating, replacing or extending Britain's Water distribution infrastructure.

It is a specification drafted by the water industry for use by the water industry and represents the experience and input of all its principal bodies: (1) The Water Authorities Association: (2) The Water Companies: (3) Water Research Centre: (4) Department of the Environment: (5) the Manufacturer's: and (6) The British Standards Institution Quality Assurance Division

### STRINGENT TESTING AND VALIDATION

Range rationalization: more stringent test procedures: greater emphasis on the validation of test data and the introduction of new performance tests are key elements of the new standard.

#### (a) Pipe Diameters and Pressure Classes

The wide range of pipe diameters and pressure classes covered in the old standard has now been rationalized because water industry practice indicate that some diameters and the lower pressure classification are rarely, if ever, used.

#### (b) Improved Test Procedures

The procedure for the 20°C Burst Test and the Impact Test have been significantly improved to give a more statistically sound result. An additional 6e0C Burst Test requirement has been introduced to monitor process control conditions.

The Test for effects on water quality have been broadened to embrace E.E.C. and World Health Organisation guidelines.

### B.S EN 1452-2: 2009 - IMPLICATIONS FOR THE WATER INDUSTRY

B.S. EN 1452-2:2009 embodies 25 years experience and calls for much more stringent testing of UPVC pressure pipe. It, therefore, provides the water industry with greater confidence than ever before in the specification of these products

The standard has the full endorsement of the water industry and it will provide tangible benefits in terms of reduced maintenance, lower failure rates and increase asset life. It is a standard which points directly towards a further increase in the percentage of UPVC pipes built into our infrastructure.

B.S. EN 1452-2:2009 " Specification for unplasticized PolyVinyl Chloride (UPVC) pressure pipes for cold potable water".



# WATERMAIN uPVC PRESSURE PIPE

## PIPES

Qualities, including lightness, ease of transport, simplicity of jointing, speed of laying and cost effective installation have enabled UPVC Pipe Systems to make a dynamic contribution to water engineering in the United Kingdom and Overseas.

The unique properties of UPVC make Hepworth Watermain pipes, joints and bends an ideal choice where potable water or other liquids are transported under pressure.

Hepworth products are manufactured to British Standard Specifications under the supervision of the Kitemark Approval Scheme. Hepworth holds 13 Kitemark Licences which indicates the stringent levels of quality control in operation. At Hepworth we do not merely pay lip service to quality, it is engineered into our products.

Hepworth Watermain pipes, joints and bends can solve many engineering problems whilst reducing overall costs because of their inherent properties of lightness, corrosion resistance and robustness. These coupled with precision manufacture will ensure maximum operational efficiency at economical laid costs.

## PIPES

Hepworth Watermain pipes are exclusively available in the full range of nominal diameters from 3/8" for household supply pipe to nominal diameters 24" truck main. Nominal working pressure classes of PN 9,12 and 15 are available in combinations of size I class as indicated in the product availability matrix. Our pipe is manufactured to B.S. EN 1452-2:2009 (Kitemark Licence number 3820).

Hepworth Watermain pipes have excellent chemical resistance properties which render them suitable for use with aggressive liquids as in corrosive environmental conditions.

The smoothness of the material coupled with precision manufacture, gives a pipe bore which retains a low roughness value throughout its working life.

Good abrasion resistance and thermal and electrical insulation are additional benefits which have helped ensure the extensive use of Hepworth Watermain for applications such as portable water supply, raw water supply, irrigation and the transportation of aggressive liquids.



# WATERMAIN uPVC PRESSURE PIPE

BS EN 1452-2:2009 STANDARD formally BS 3505:1986  
(Kitemark) for Size 1/2" to 12"

NOMINAL DIAMETER	WORKING PRESSURE / CLASS			LENGTH AVAILABLE 6m
	PN 9	PN 12	PN 15	
3/8	—	—	●	●
1/2	—	—	●	●
3/4	—	—	●	●
1	—	—	●	●
1 1/4	—	●	●	●
1 1/2	—	●	●	●
2	●	●	●	●
3	●	●	●	●
4	●	●	●	●
5	●	●	●	●
6	●	●	●	●
8	●	●	●	●
10	●	●	●	●
12	●	●	●	●
14	○	●	●	●
16	○	●	●	●
18	○	●	—	●
20	○	○+	—	●
24	○	—	—	●

KEY ● Available from stock  
○ Available to order  
— Not available  
○+ Non British Standard

The above matrix shows pipe in standard 6 metre lengths which is the current preferred length used by the UK Water Industry. Other lengths may be available.

NOMINAL DIAMETER	MEAN OUTSIDE DIAMETER		WALL THICKNESS								
			PN 9 90m HEAD OF WATER CLASS C			PN 12 120m HEAD OF WATER CLASS D			PN 15 150m HEAD OF WATER CLASS E		
			averaged value	individual value		averaged value	individual value		averaged value	individual value	
min. mm	max. mm	max. mm	min. mm	max. mm	max. mm	min. mm	max. mm	max. mm	min. mm	max. mm	
3/8	17.0	17.3	—	—	—	—	—	—	1.9	1.5	1.9
1/2	21.2	21.5	—	—	—	—	—	—	2.1	1.7	2.1
3/4	26.6	26.9	—	—	—	—	—	—	2.5	1.9	2.5
1	33.4	33.7	—	—	—	—	—	—	2.7	2.2	2.7
1 1/4	42.1	42.4	—	—	—	2.7	2.2	2.7	3.2	2.7	3.2
1 1/2	48.1	48.4	—	—	—	3.0	2.5	3.0	3.7	3.1	3.7
2	60.2	60.2	3.0	2.5	3.0	3.7	3.1	3.7	4.5	3.9	4.5
3	88.7	89.1	4.1	3.5	4.1	5.3	4.6	5.3	6.5	5.7	6.6
4	114.1	114.5	5.2	4.5	5.2	6.8	6.0	6.9	8.3	7.3	8.4
5	140.0	140.4	6.3	5.5	6.4	8.3	7.3	8.4	10.1	9.0	10.4
6	168.0	168.5	7.5	6.6	7.6	9.9	8.8	10.2	12.1	10.8	12.5
8	218.8	219.4	8.8	7.8	9.0	11.6	10.3	11.9	14.1	12.6	14.5
10	272.6	273.4	10.9	9.7	11.2	14.3	12.8	14.8	17.5	15.7	18.1
12	323.4	324.3	12.9	11.5	13.3	17.0	15.2	17.5	20.8	18.7	21.6
14	355.0	356.0	14.1	12.6	14.5	18.6	16.7	19.2	22.8	20.5	23.6
16	405.9	406.9	16.2	14.5	16.7	21.1	19.0	21.9	26.0	23.4	27.0
18	456.7	457.7	18.2	16.3	18.8	23.8	21.4	24.6	—	—	—
20	507.5	508.5	20.2	18.1	20.9	—	—	—	—	—	—
24	609.1	619.1	24.1	21.7	25.0	—	—	—	—	—	—

KEY

CLASS	PN	MTS HEAD	PSI
C	9	90	130.5
D	12	120	174
E	15	150	217.5



For irrigation, drainage and for cable ducting.  
Stocks are available with plain ends or with sockets in standard length of 6m.  
Working pressures given are based on a temperature of 20°C. uPVC pipes derate at higher temperature.

# WATERMAIN uPVC PRESSURE PIPE

## uPVC PIPES (METRIC SERIES) MANUFACTURED IN ACCORDANCE TO ISO 161-1

<b>UPVC Metric Series pipes ISO 161-1</b>			
<b>Nominal outside diameter (dn)</b>	<b>PN-6</b>	<b>PN-10</b>	<b>PN-16</b>
	SDR-41	SDR-26	SDR-17
	<b>Minimum Wall Thickness (mm)</b>		
20	-	-	1.4
25	-	-	1.5
32	-	-	1.9
40	-	1.6	2.4
50	-	2	3.0
63	1.6	2.5	3.8
75	1.9	2.9	4.5
90	2.2	3.5	5.4
110	2.7	4.2	6.6
125	3.1	4.8	7.4
140	3.5	5.4	8.3
160	4	6.2	9.5
200	4.9	7.7	11.9
225	5.5	8.6	13.4
250	6.2	9.6	14.8
280	6.9	10.7	16.6
315	7.7	12.1	18.7
400	9.8	15.3	23.7

For water supply, irrigation, drainage mains and for cable ducting

Available in standard length of 6 metres with plain ends ,pushfit rubber ring (for dia  $\geq$  75mm) or solvent socket ends.

Working pressures given are based on a temperature of 20° C .

# WATERMAIN uPVC PRESSURE PIPE

## uPVC PRESSURE PIPES (METRIC SERIES) MANUFACTURED IN ACCORDANCE TO BS EN 1452

Nominal outside diameter <i>d</i> n	Nominal (minimum) Wall Thickness					
	Pipe series S					
	S 20 (SDR 41)	S 16 (SDR 33)	S 12.5 (SDR 26)	S 10 (SDR 21)	S 8 (SDR 17)	S 6.3 (SDR 13.6)
	Nominal pressure PN Base on service (design) coefficient C=2.5					
		PN6		PN10		PN16
20	-	-		-		1.5
25	-	-		-	1.5	1.9
32	-	-	1.5	1.6	1.9	2.4
40	-	1.5	1.6	1.9	2.4	3.0
50	-	1.6	2.0	2.4	3.0	3.7
63	-	2.0	2.5	3.0	3.8	4.7
75	-	2.3	2.9	3.6	4.5	5.6
90	-	2.8	3.5	4.3	5.4	6.7
	Nominal pressure PN Base on service (design) coefficient C=2.0					
	PN6		PN10		PN16	
110	2.7		4.2		6.6	
125	3.1		4.8		7.4	
140	3.5		5.4		8.3	
160	4.0		6.2		9.5	
180	4.4		6.9		10.7	
200	4.9		7.7		11.9	
225	5.5		8.6		13.4	
250	6.2		9.6		14.8	
280	6.9		10.7		16.6	
315	7.7		12.1		18.7	
355	8.7		13.6		21.1	
400	9.8		15.3		23.7	

Note 1: The nominal wall thicknesses conform to ISO 4065:1996

Note 2: The PN 6 values for S 20 and S 16 are calculated with the preferred number 6.3.



# WATERMAIN uPVC PRESSURE PIPE

uPVC Pressure Pipes (Metric series) Manufactured in accordance to DIN 8061 / 62														
Nominal outside diameter (dn)			PN - 4			PN - 6			PN - 10			PN - 16		
Size	Min (dn)	Max (dn)	Minimum WT (mm)	Maximum WT (mm)	Wgt / Mtr (Kg / Mtr)	Minimum WT (mm)	Maximum WT (mm)	Wgt / Mtr (Kg / Mtr)	Minimum WT (mm)	Maximum WT (mm)	Wgt / Mtr (Kg / Mtr)	Minimum WT (mm)	Maximum WT (mm)	Wgt / Mtr (Kg / Mtr)
20	20	20.2	-	-	-	-	-	-	-	-	-	1.50	1.90	0.137
25	25	25.2	-	-	-	-	-	-	-	-	-	1.90	2.30	0.212
32	32	32.2	-	-	-	-	-	-	16.0	2.00	0.243	2.40	2.90	0.342
40	40	40.2	-	-	-	-	-	-	19.0	2.30	0.350	3.90	3.60	0.525
50	50	50.2	-	-	-	1.50	1.90	0.366	2.40	2.90	0.552	3.70	4.30	0.809
63	63	63.3	-	-	-	1.90	2.30	0.562	3.00	3.60	0.854	4.70	5.40	1.290
75	75	75.3	1.50	1.90	0.556	2.20	2.70	0.782	3.60	4.20	1.220	5.60	6.40	1.820
90	90	90.3	1.80	2.20	0.774	2.70	3.20	1.130	4.30	5.00	1.750	6.70	7.60	2.610
110	110	110.4	2.20	2.70	1.160	3.20	3.80	1.640	5.30	6.10	2.610	8.10	9.20	3.900
125	125	125.4	2.50	3.00	1.480	3.70	4.30	2.130	6.00	6.90	3.340	9.20	10.40	5.010
140	140	140.5	2.80	3.30	1.840	4.20	4.80	2.650	6.70	7.60	4.180	10.30	11.60	6.270
160	160	160.5	3.20	3.80	2.410	4.70	5.40	3.440	7.70	8.70	5.470	11.80	13.20	8.170
180	180	180.5	3.60	4.20	3.020	5.30	6.10	4.370	8.60	9.70	6.880	13.30	14.90	10.400
200	200	200.6	3.90	4.60	3.670	5.90	6.70	5.370	9.60	10.80	5.510	14.70	16.40	12.800
225	225	225.7	4.40	5.10	4.670	6.60	7.50	6.760	10.80	12.10	10.800	16.60	18.50	16.100
250	250	250.8	4.90	5.60	5.650	7.30	8.30	8.310	11.90	13.30	13.200	18.40	20.50	19.900
280	280	280.9	5.50	6.30	7.110	8.20	9.30	10.400	13.40	15.00	16.600	20.60	22.90	24.900
315	315	316.0	6.20	7.10	9.020	9.20	10.40	13.200	15.00	16.70	20.900	23.20	25.80	31.500
355	355	356.1	7.00	8.00	11.400	10.40	11.70	16.700	16.90	18.80	26.500	26.10	29.00	39.900
400	400	401.2	7.90	8.90	14.500	11.70	13.10	21.100	19.10	21.30	33.700	29.40	32.60	50.800

For water supply, irrigation, drainage mains and for cable ducting

Available in standard length of 6 metres with plain ends ,pushfit rubber ring (for dia  $\geq$  75mm) or solvent socket ends.

Working pressures given are based on a temperature of 20° C .

# WATERMAIN uPVC PRESSURE PIPE





# WATERMAIN uPVC PRESSURE PIPE

## JOINTS

Hepworth Watermain offers a choice of jointing methods to suit the particular needs of the Specifying Engineer, Purchasing Officer and Contractor.

Integral joints of the mechanical or solvent weld type are available, as are mechanical couplings for use with plain ended pipe.

The Hepworth Watermain Loc-Ring integral socket has achieved worldwide recognition because of its innovative and unique design. Manufactured to the highest standards the sockets incorporate a triple compression seal which is resistant to both positive and negative pressures. As a safeguard against misuse, the rubber sealing ring is inserted and locked into position during manufacturing and arrives on site with in built-in security ready for immediate use, to ensure that a quick and reliable joint is made.

The Loc-Ring integral joint is suitable for operation at the same nominal working pressures as the parent pipe and is available in the range of nominal diameters 2" to 12"

The Loc-Ring coupling is manufactured to the same high standards of precision as the integral socket and incorporates all its unique design features.

The couplings are intended for use with plain ended pipe lengths where economy of use is paramount. They allow complete utilization of pipe cut-lengths and are particularly useful where multiple connections are anticipated.

The Loc-Ring integral sockets and Loc-Ring couplings listed in the product availability matrices are manufactured to B.S. EN 1452-2:2009 and are covered by Kitemark Licence number KM506021

The Hepworth Watermain solvent weld integral socket is recommended for use where resistance to end-loading cannot be provided by anchor thrust-blocks for example above-ground installations, and poor ground conditions.

It is also particularly suited to slip-lining applications where the slim profile ensures minimum bore reduction, coupled with ease of installation.

Sizes greater than nominal diameter 12" can be supplied to consultation with the Hepworth Watermain Sales Office.



# WATERMAIN uPVC PRESSURE PIPE

## LOC-RING INTEGRAL JOINT

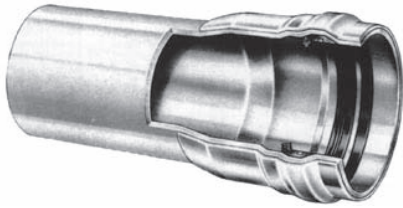

Hepworth unique Loc-Ring Integral joint with triple seal security.

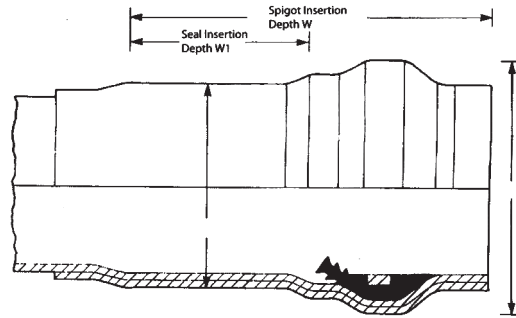

NOMINAL DIAMETER	WORKING PRESSURE / CLASS - AVAILABILITY		
	PN 9	PN 12	PN 15
2	●	●	●
3	●	●	●
4	●	●	●
5	●	●	●
6	●	●	●
8	●	●	●
10	●	●	●
12	●	●	●
14	●	●	●
16	●	●	●
18	●	●	—
20	●	○+	—
24	●	●	—

KEY ● Available from stock  
○ Available to order  
— Not available  
○+ Non British Standard



NOMINAL DIAMETER	INSERTION DEPTH W min mm	SEAL INSERTION DEPTH W min mm	SOCKET OUTSIDE DIAMETER X max mm	SLEEVE OUTSIDE DIAMETER Y max mm
3	142	58	130	105
4	155	58	156	135
5	165	63	190	164
6	182	68	226	202
8	207	79	278	250
10	234	84	343	315
12	251	89	404	373
14	261	114	438	408
16	280	119	500	468
18	297	137	559	525
20	313	140	616	581
24	359	165	730	690

KEY

CLASS	PN	MTS HEAD	P.S.I
C	9	90	130.5
D	12	120	174
E	15	150	217.5

## LOC-RING COUPLING

### THE WATERMAIN LOC-RING COUPLING

Nom. Size	L Min. mm	L1 Min. mm	L2 Min. mm	X Max. mm	Maximum Working Pressure	
					bar	m/hd
110	112	45	277	146	12	120
160	153	50	360	217	12	120
200	173	55	417	268	12	120
250	188	60	459	332	12	120
315	210	70	526	392	12	120

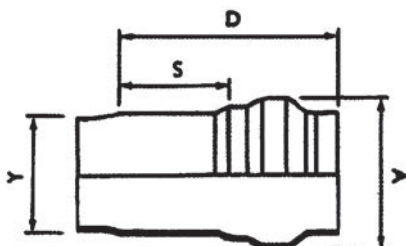
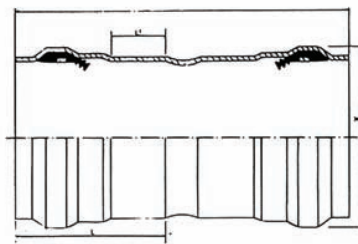

NOMINAL DIAMETER (INCHES)		90	110	160	200	250	315
D - Insertion depth	min	142	155	182	207	234	251
S - Seal Depth	min	58	58	68	79	84	89
A - Socket Outside Diameter	max	130	156	226	278	343	404
Y - Sleeve Outside Diameter	max	105	135	202	250	315	373



# WATERMAIN uPVC PRESSURE PIPE

## FLOW DATA

### FLOW CHART FOR uPVC PIPES NOMINAL DIAMETER 3/8 TO 24

The accompanying flow chart has been calculated on the mean bore of UPVC pipes manufactured in different classes according to PN Rating BSEN1452: 2: 2009. These standards are based on pipes made to inch diameters and the diagram has been prepared on the basis of Imperial units; metric equivalents of velocity and a separate scale for rate of flow in litres per second are incorporated.

The smooth bore of UPVC pipes, which are not subject to modulation, together with long pipe lengths, enables them to be treated as hydraulically smooth where they are used for the conveyance of potable water supply. Sewage pumping mains are in certain circumstances, liable to acquire coatings of limes which may reduce their flow capacity.

To use the chart it is only necessary to visually locate the appropriate intersection points to ascertain the relationship between pipe dimension, flow and loss of head and if required, the mean velocity of flow.

The charts has been prepared using the **Colebrook = White Flow equation.**

$$V = -2 \sqrt{2gDi} \cdot \text{Log} \left( \frac{Ks}{3.7D} + \frac{2.51\vartheta}{D \sqrt{2gDi}} \right)$$

Where

V = velocity in metres per second

g = gravitational acceleration ( a value of 9.807 M/s/s has been assumed)

i = Hydraulic gradient

$\vartheta$  = Kinetic Viscosity (a value of  $1.141 \times 10^{-6}$ )

Ks = linear measure of roughness in mm. = 0.003 mm

D = mean internal diameter of pipe (manufactured to B.S. EN 1452-2 : 2000)

### K. VALUE

The frictional losses occasioned by flow through fittings are approximately proportional to the square of the liquid velocity.

The losses can be determined by the use of the following formula.

$$H = \frac{Kv^2}{2g}$$

Where

H = loss of head

v = liquid velocity

g = acceleration due to gravity

K = coefficient dependent on type of fitting

Various Values for K are:-

90° Elbow	K = 1.00
45° Elbow	K = 0.4
22½° Elbow	K = 0.2
90° Bend	K = 0.2
45° Bend	K = 0.1
22½° Bend	K = 0.05
90° Tee flow in line	K = 0.35
90° Tee flow into or from ranch	K = 1.20
Gate valve : open	K = 0.12
¼ closed	K = 1.0
½ closed	K = 6.0
¾ closed	K = 24.0
Globe valve : open	K = 10.0
Butterfly valve : open	K = 0.3

# WATERMAIN uPVC PRESSURE PIPE

## FLOW CHART FOR PVC-U PIPES

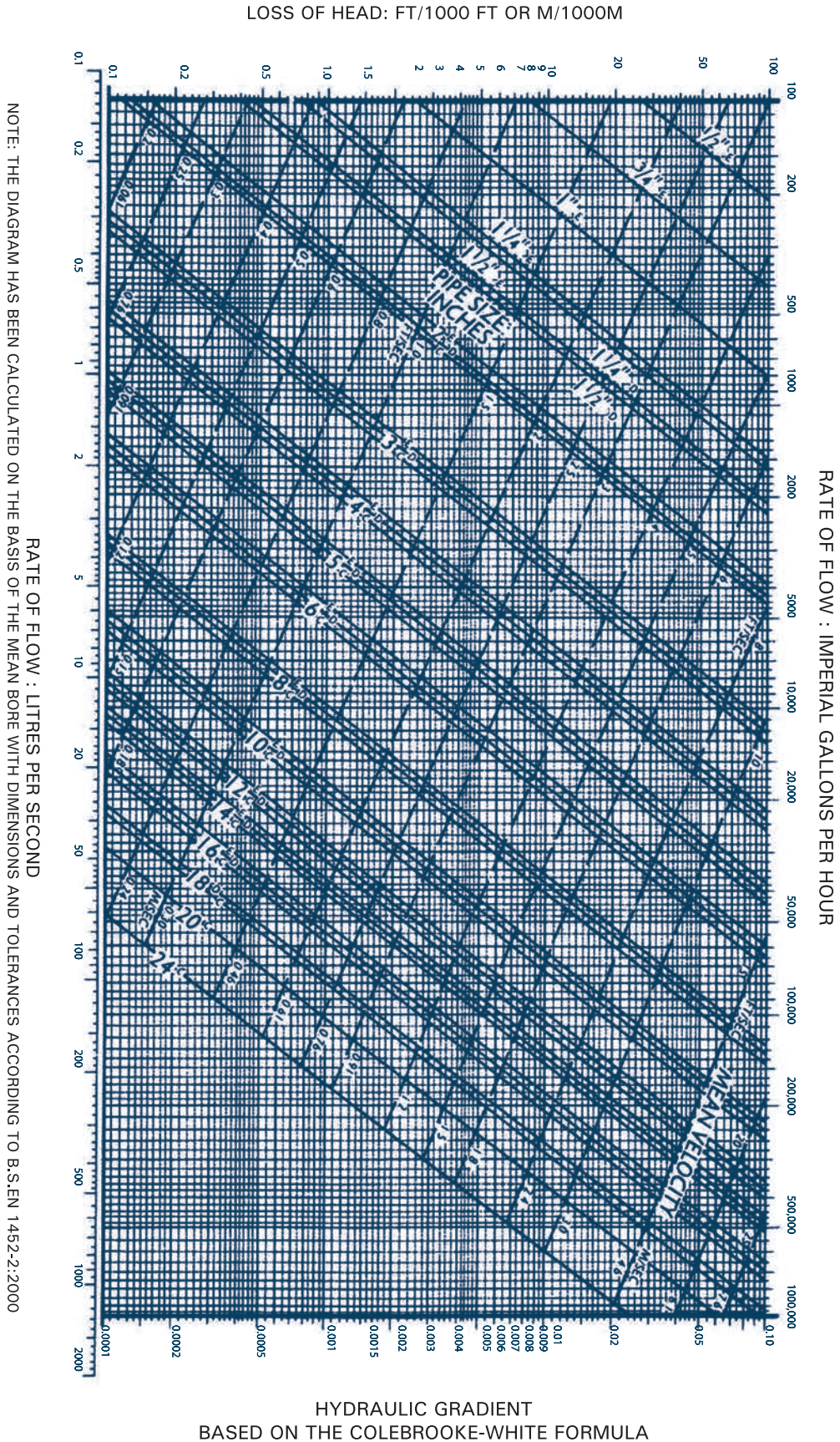



# WATERMAIN uPVC PRESSURE PIPE

## TRENCH WORK

The line and level of the pipe and hence buried depth of the pipeline, will have been predetermined at the design stage.

The trench should not be excavated too far in advance of pipe laying and should be backfilled as soon as possible, **however joints should be left exposed until testing has been successfully completed.**

The width of the trench at ground level will depend on the type of subsoil and buried depth of the pipeline. The minimum width of the trench at the pipe springing line should be as narrow as practicable but not less than the pipe diameter plus 300mm. The maximum width of the trench at the crown of the pipe must not exceed the pipe diameter plus 600mm.

### TRENCH FORMATION

#### a) DIRECT LAYING

If the pipe is to be laid directly onto the trench bottom make sure that the trench formation is composed of:-

Stable, uniform, fine-grained soil, with no large flints or stones, or other protuberances which might cause point-loading on the pipe.

When laying the pipe directly the trench formation should be trimmed to an even finish which will provide continuous support to the pipe. Additional excavation will be required at the position of the pipe sockets to ensure proper joint assembly and pipe support.

#### b) PIPE LAYING ON BEDDING

If the formation is unsuitable for direct laying the trench will need to be excavated to a further depth of minimum of 100 mm below the underside of the pipe.

This should be made up with a suitable bedding material as defined on page 1 8 in extreme conditions such as waterlogged or unstable ground it may be necessary to increase the thickness of the bedding material.

If guidance is required please consult our Technical Department. Pipelines laid through rock should always be laid on a minimum of 100 mm bed of suitable bedding materials.

## TRENCH WORK

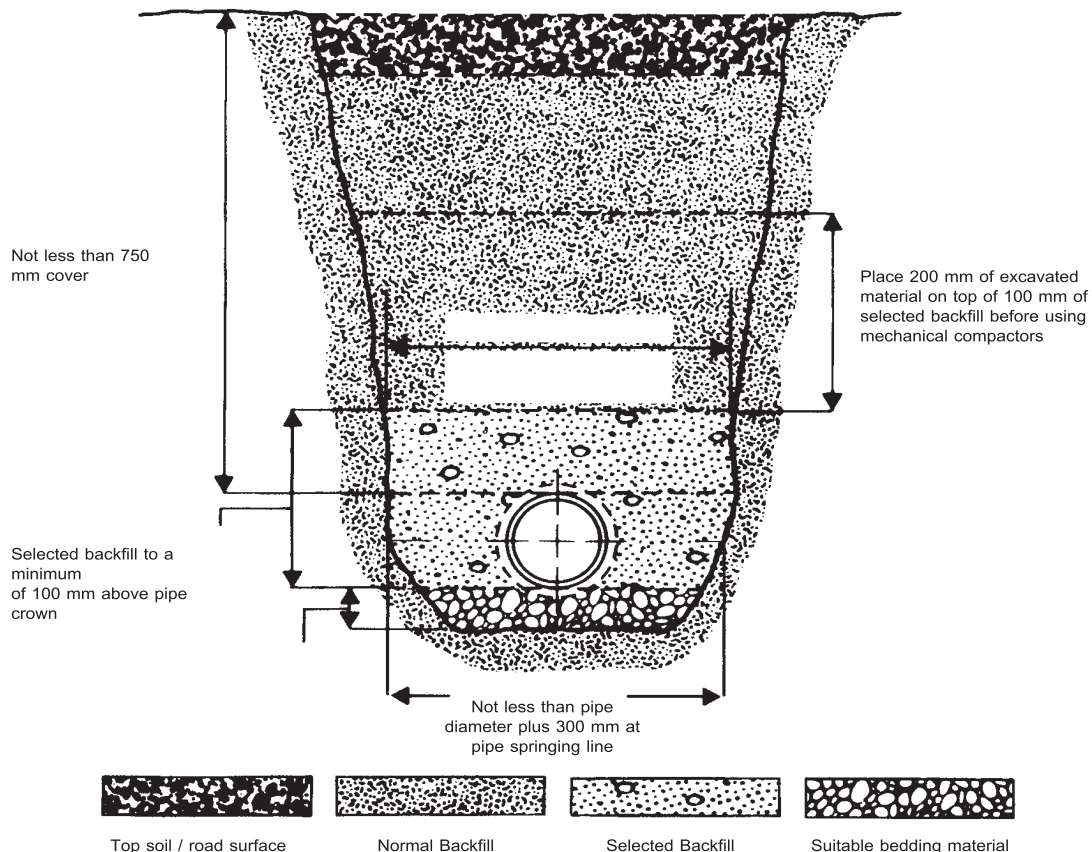

# WATERMAIN uPVC PRESSURE PIPE

## BEDDING MATERIAL

The bedding material selected may be available from excavated trench material or may need to be imported from another source. The material should be granular in nature, free from large stones, debris or frozen matter, and preferably fine grained in nature. Materials such as clay or hard chalk will break up when wetted should not be used. Suitable materials are free draining coarse sand and nominal single size gravel with rounded or angular particles gravels should be nominal single size 10 mm or 5 to 10 mm graded, preferably with angular particles which have good self compacting properties.

The bedding material should be placed carefully in the trench and properly compacted by hand to ensure a sound continuous bed for the pipes. Particular attention should be paid to the socket holes to ensure correct placement and compaction of bedding material in this area. **Bricks or other forms of temporary pipe support should never be left in the trench.**

## BACKFILL

Following satisfactory bedding and pipe laying, selected material should be placed in the trench in layers not exceeding 100 mm, each layer being thoroughly compacted by hand. The selected material should have a maximum particle size of 75 mm and be free from topsoil, stones, tree roots and other debris which may be harmful to the pipe. The initial backfilling of selected material should continue to a minimum height of 100 mm above the crown of the pipe.

Above this level normal backfilling procedures should be adopted including compaction to prevent subsequent settlement of the trench infill. Heavy mechanical compactors should not be used until there is a minimum 300 mm layer of material above the crown of the pipe. Any trench sheeting should be carefully withdrawn during the backfilling and infill process, to allow proper compaction to occur.





# WATERMAIN uPVC PRESSURE PIPE

## PIPE LAYING AND JOINTING

### ( Push - fit Joint )

The jointing techniques required for the Watermain System involves simple procedures which will be carried out successfully if these instructions are followed. However, problems can arise if these instructions are not followed which may result in unacceptable installation. The instruction which follow should be adhered to in all normal circumstances. In other cases or special applications please consult our Technical Department.

#### WATERMAIN LOC-RING SOCKET AND COUPLING

**1** The spigot and socket to be joined should be carefully examined for any damage which would pair the jointing procedure. Particular attention should be paid to spigot chamfer and the sealing ring. The pipe should be chamfered to a depth of half the wall thickness and at an inclination angle of 15° to the pipe axis. If pipes are cut on site they should be cut square to the pipe axis with a fine toothed saw and chamfered to half the pipe wall thickness with a coarse file or Surform tool. The chambered spigot should be clean and free from swarf and burrs. The sealing ring should be correctly seated in the socket groove, complete with the uPVC insert ring. The sealing portion of the ring must be from damage of any sort. Joints containing damaged or incorrectly fitted rings must not be used.

**2** The spigot insertion depth should be measured as the depth from the mouth to the depth from the mouth to shoulder of the socket. The spigot should be marked accordingly using an inedible crayon. If an allowance for expansion is required, (eg. where changes in operating temperature are anticipated), this should be deducted from the spigot insertion depth.

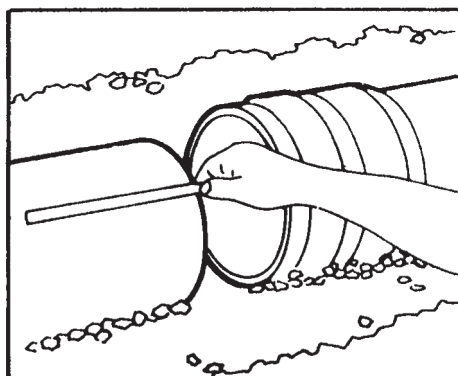
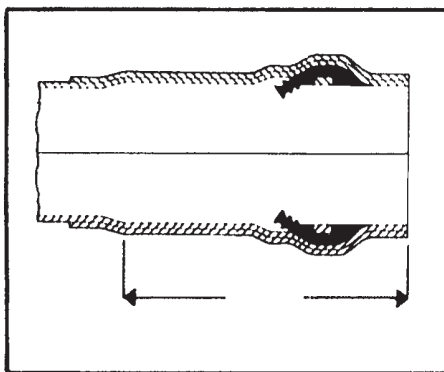

**3** The mating areas of the spigot and socket should be thoroughly cleaned. All grease, dirt, swarf and other foreign matter should be removed from the sealing areas. **If water is used in the cleaning operation, it is essential that the mating areas are thoroughly dried before the next stage of jointing is commenced.**

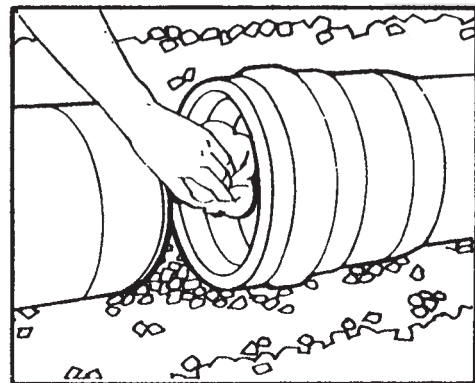

**4** The spigot end and triple sealing portion of the sealing ring should be lubricated with the Watermain lubricant supplied with the pipe. The spigot should be lubricated to the full insertion depth and around its complete circumference, paying particular attention to the chamber area. The triple seal should be lubricated around its complete circumference. The guiding principle should be to apply a liberal quantity of applicant and avoid dry areas on the mating surfaces.

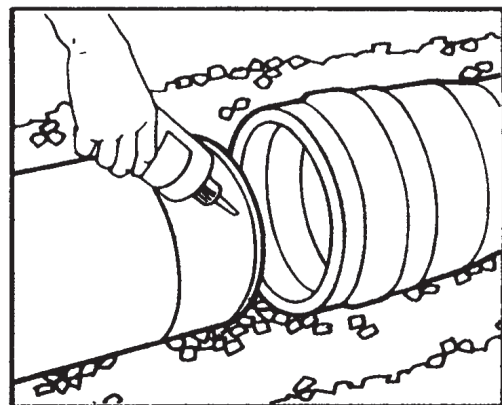

**5** Immediately after lubrication, the spigot should be brought into contact with the socket. The spigot pipe and parent joint should be accurately aligned so that axis of pipes are precisely in line. The spigot should be hand fed into the socket until resistance from the inner sealing selection is felt. Correct alignment at this stage is essential to ensure that the rubber sealing ring is not pinched or torn.

# WATERMAIN uPVC PRESSURE PIPE

## PIPE LAYING AND JOINTING

The joint can now be completed by one of the methods described below.

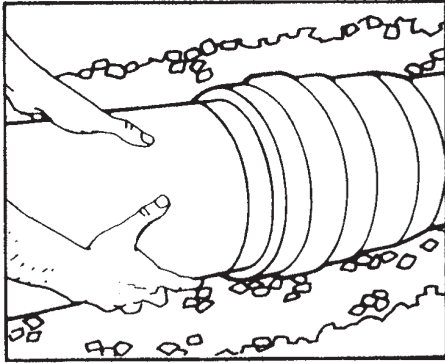

### 6 a) LEVERAGE METHOD

Sizes up to nominal diameter 8" can normally be jointed by applying leverage with a crow bar at the following socket end. A stout timber should be inserted between the crow bar and the pipe socket to prevent damage to the latter. The leverage should be applied in a steady, continuous manner until the spigot insertion depth mark coincides with the mouth of the socket being jointed. No further leverage should be applied. If any undue resistance is felt and the spigot can't be levered home, the joint should be disassembled and examined to determine possible causes (e.g. lack of lubrication and pinched or trapped sealing ring). The procedure should then be repeated as described above.

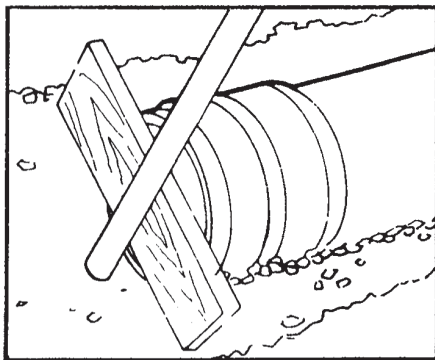

### a) JOINTING CLAMPS

Are available for sizes above nominal size 8 and are specially designed for use with Hepworth uPVC Pressure Pipes. These are particularly useful where bends are to be installed in the pipeline. The clamps should be positioned so that one clamp is adjacent to the socket shoulder and the other close to, but not overlapping the depth insertion mark.

Once assembled with the steel tie wires in place, a simple ratchet

action will draw the spigot into the socket mouth. The spigot should be correctly aligned as described above and drawn into the socket. No further pulling should take place. The clamps incorporate protective pads to prevent gouging and scratching of the pipe surface. The clamps must not be used without the protective pads.

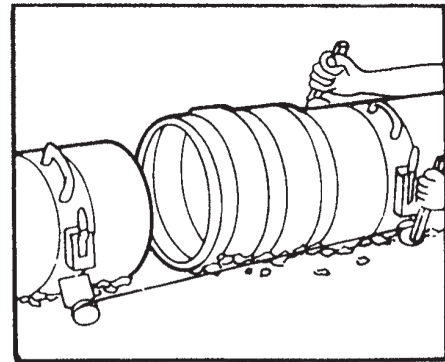

### c) OTHER FORMS OF LEVERAGE

Other types of pulling device are commonly used.

When these or the methods described above are employed the following fundamental points should be remembered.

- i) Proper lubrication of the spigot and the sealing ring is essential.
- ii) Correct alignment between the axes of the two pipes must be achieved.
- iii) Excessive force applied during jointing can seriously affect the performance of the completed joint.
- iv) The spigot must not be inserted beyond the depth insertion mark.

AVERAGE QUANTITIES OF SOLVENT CEMENT, CLEANER AND LUBRICANT REQUIRED FOR uPVC PIPE JOINTS USING 500 ML CONTAINERS

SOLVENT CEMENT		SOLVENT CLEANER		LUBRICANT FOR UPVC PIPES WITH RING JOINTS	
Size of Pipe	Qty (500ML)	Size of Pipe	Qty (500ML)	Size of Pipe	Qty (500ML)
3/8"	262	3/8"	174.7	0	0
1/2"	212	1/2"	141.35	0	0
3/4"	168	3/4"	112	0	0
1"	134	1"	89.35	0	0
1 1/4"	86	1 1/4"	57.35	0	0
1 1/2"	62	1 1/2"	41.35	0	0
2"	38	2"	25.35	2"	50
2 1/2"	24	2 1/2"	16	2 1/2"	0
3"	17	3"	11.35	3"	44
4"	10	4"	6.7	4"	39
5"	6.5	5"	4.35	5"	26
6"	4.5	6"	3	6"	22
7"	3.4	7"	2.3	7"	20
8"	2.6	8"	1.75	8"	16
9"	2	9"	1.35	9"	13
10"	1.7	10"	1.15	10"	11
12"	1.2	12"	0.8	12"	9
14"	0.9	14"	0.6	14"	7
16"	0.7	16"	0.5	16"	6
18"	0.6	18"	0.4	18"	5
				20"	4
				22"	3
				24"	3

# WATERMAIN uPVC PRESSURE PIPE

## PIPE LAYING AND JOINTING

### ( Solvent Weld Joint )

#### WATERMAIN SOLVENT WELD SOCKET

**1** The spigot and socket to be jointed should be carefully examined for any damage which would impair the jointing procedure. Particular attention should be paid to the spigot chamfer as for Loc-Ring jointing procedure.

**2** The spigot insertion depth should be measured as the depth from the mouth to the shoulder of the socket. ( See below ) The insertion depth should be then be marked on the spigot using an indelible crayon

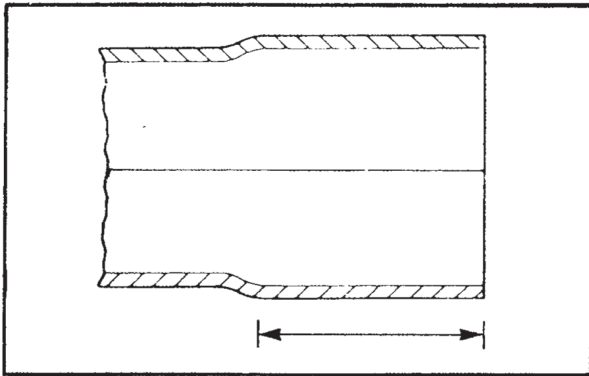

**3** The mating areas of the spigot and socket should be thoroughly cleaned using the Watermain Cleaning Fluid provided and a clean rag or absorbent paper.

N.B. Man-made fibres must not be used to clean joints which are to be solvent welded.

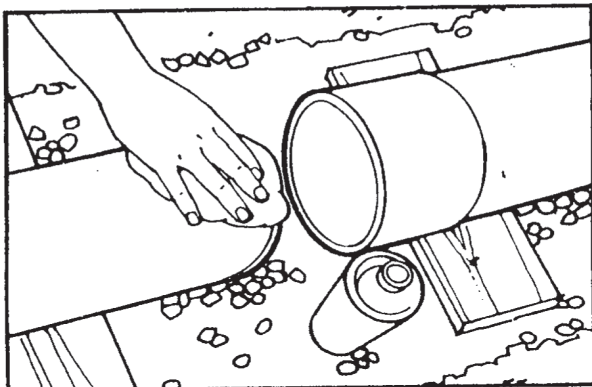

**4** Lightly roughen the mating surfaces of the spigot and socket, using clean emery cloth or medium glass paper.

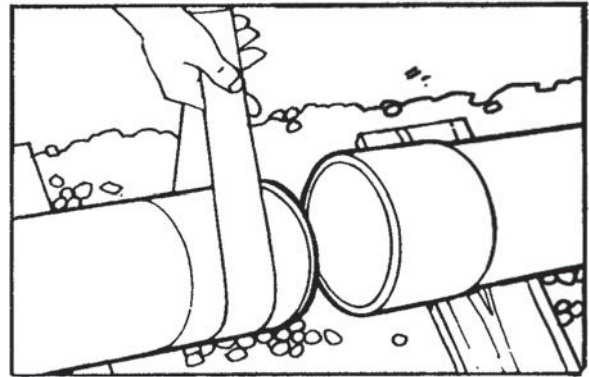

**5** Thoroughly clean again the mating surfaces using the Watermain Cleaning Fluid provided and a clean rag or absorbent paper. Ensure that all mating surfaces are clean and completely dry.

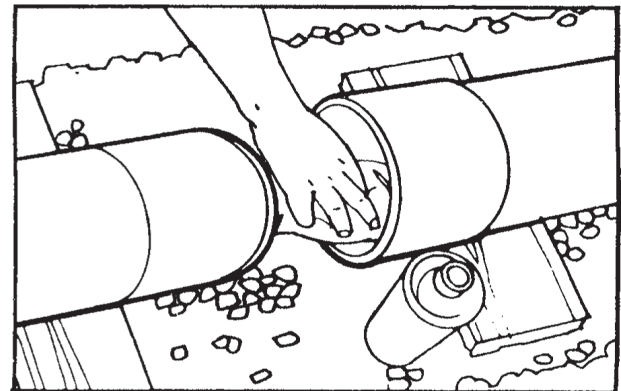

**6** Using a brush of the size recommended - ( see Page 33 ) apply an even layer of Watermain Solvent Cement to the spigot and socket mating surfaces. The cement should be applied in a lengthwise direction and NOT with a circular motion. For joints of nominal diameter 3 and above, the cement should be applied simultaneously to the spigot and socket by two people.

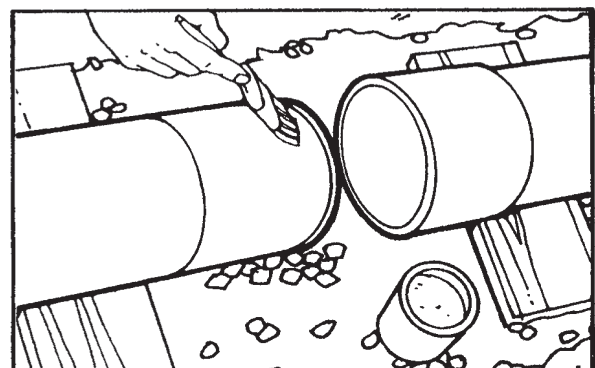

# WATERMAIN uPVC PRESSURE PIPE

## PIPE LAYING AND JOINTING

**7** Immediately following cement application ensure that the parent pipe is suitably anchored, and push the spigot fully home in the socket without turning the pipe. The spigot should be inserted with a steady, continuous motion and held in place for 20 seconds. Remove the surplus cement from around the mouth of the socket.

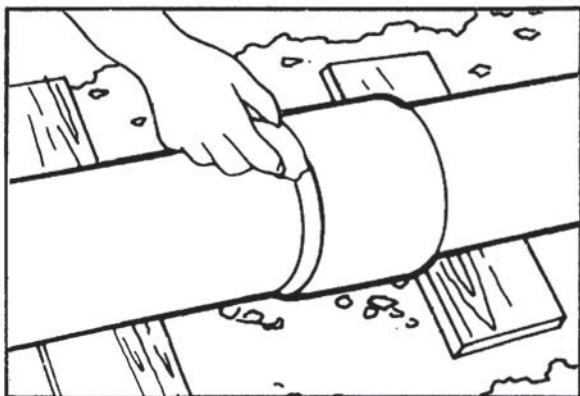
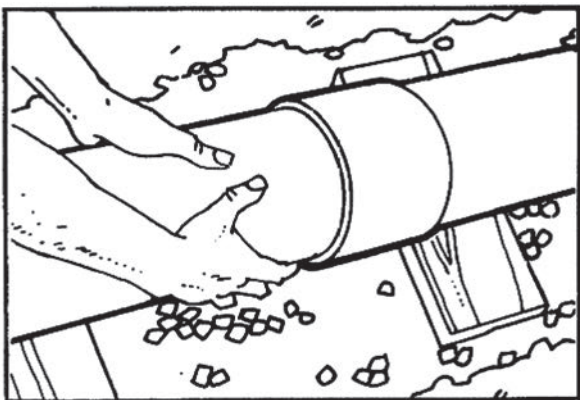

**8** Leave the joint undisturbed for five minutes, then handle with reasonable care. N.B. See Inspection and Testing, Page 29 (Thrust Forces Section).

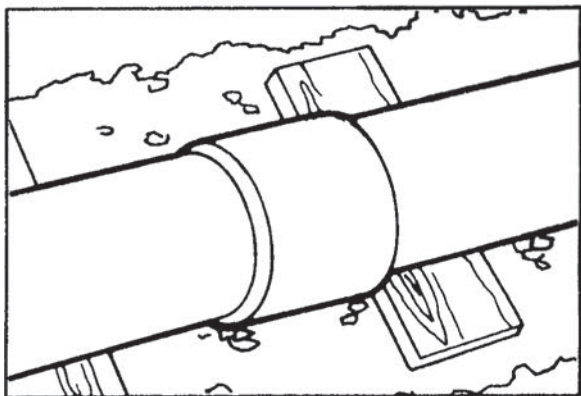

## IMPORTANT

### SOLVENT WELD NOTES

1. Solvent cement is flammable. Do not work near a naked flame or smoke in the work area.
3. Solvent cement should be used in well ventilated conditions.
3. The instructions on the tin, especially those relating to first aid should be strictly adhered to.
4. On no account must cleaning fluid be mixed with solvent cement.
5. The solvent in the cement evaporates quickly, so the tin should be closed immediately after use.
6. Do not use a brush on which solvent cement has previously hardened.
7. Solvent cement spilled on the pipe surface should be removed immediately.
8. If solvent cement is spilled in the trench or on the backfill material, the contaminated material must be removed from the working area.



# WATERMAIN uPVC PRESSURE PIPE

## DEFLECTION

The Loc-Ring Integral Socket permits an angular deflection at the joint 2/3. The introduction of joint deflection is, however, generally unnecessary in an inherently flexible uPVC pipeline. Sufficient flexibility is provided by individual pipe lengths to enable gentle curves to be negotiated without imparting deflection at the joints. As a general guide the cold bending radius (R) of uPvc pipe length can be calculated as follows:

$$R = 250 \times \text{External Diameter}$$

Where a shorter radius of curvature is required, then uPVC formed bends must be introduced.

## THERMAL MOVEMENT

Research has shown that in buried Watermain installations, below ground temperatures remain constant and little attention need be given to the accommodation of thermal movement.

It is only necessary to consider the effect of ambient temperatures during laying operations. Where solvents welded joints are being used the pipeline should be allowed to assume thermal stability after laying before final connections are made and anchor block positioned. No precautions are necessary using push-fit joints which are self correcting.

## PVC BEND

### THRUST FORCES

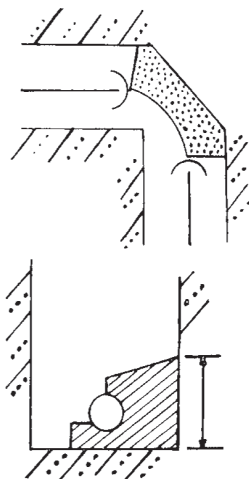

When a pipeline is constructed using push-fit joint separation due to internal pressure and resulting thrust forces must be prevented. This is achieved using concrete thrust blocks at directional changes, branches, end caps, valves, etc. The design of uPVC pipes provides a safety factor of 2: 1 after a life of 50 years at maximum working pressure. In designing thrust blocks it is logical to apply a similar factor of safety after calculating thrust forces on the maximum foreseeable line pressure.

In view of the flexible nature of uPVC it is desirable in thrust block design to permit the largest possible area of contact between the fitting concerned and the concrete blocks so that a restraint against excessive flexing as well as a thrust, is provide (Fig.1). This feature, in certain soil conditions, may also be applied to Solvent welded pipelines which need so support against thrust but which can benefit by flexing restraint at abrupt directional changes. Thrust blocks concrete should not be allowed to encase the fitting as the external diameter of a uPVC pipe must be left free to distend due to pressure fluctuation. The block may be designed as shown in fig.1 or if total encasement is preferred the fitting should first be wrapped in several layers of heavy gauge polythene film prior to concreting to provide freedom of movement and a barrier against abrasion.

## BACK-FILLING AND CONSOLIDATION

It is good practice to arrange back-filling can progress to follow closely behind main laying. uPVC pipe can be laid with such speed that backfilling can progress simultaneously with pipe-laying.

The initial pipe backfill should be of reasonably compatible material (compaction factor 0.3 or less) and free from sharp stones or other debris which, on compaction can cause detrimental point loading on the pipeline. This initial backfilling should be thoroughly compacted by hand ramming.

Mechanical ramming of subsequent backfill should not commence until at least 30 cms. of hand consolidated cover is attained. Where pipes have less than 76 cms. of cover, consideration should always be given to the likelihood of heavy vehicular traffic loadings.

The encasement of uPVC pipe in concrete is both wasteful and destructive. It converts a tough flexible pipeline into a grid beam of limited flexural strength. At cover depths of 60 cm and more, protection by normal, well compacted granular surround is generally adequate. At shallower cover depths under roads, protection is best afforded by use of concrete slabs upon a cushion of granular fill or by passing the pipeline through a protective pipe duct of greater diameter.

# WATERMAIN uPVC PRESSURE PIPE

## INSTALLATION - ABOVE GROUND

Where uPVC Watermains or services are specified for above ground situations the following notes should be considered where applicable.

## FROST PROTECTION

Like most materials uPVC becomes prone to impact damage as the temperature drops below zero. Pipe-runs should therefore be sited or protected in such manner as will prevent accidental damage in conditions of extreme cold.

Due to the extremely low thermal conductivity of the material it is unlikely that the contents of a uPVC pipeline will freeze in normal UK winter temperatures. However, abnormal climatic conditions and periods of "no-flow" should be considered and exposed pipe work lagged accordingly.

## WORKING PRESSURE

The maximum pressure ratings of uPVC pipes have been calculated on the basis that the pipeline temperature is no greater than 20°C. Where this pipe temperature is likely to be exceeded then the maximum pressure rating must be reduced if the full operational life-expectancy of the pipeline is to be maintained.

It is unlikely that such modification will be necessary due to mains water temperatures, but where a Watermain is in an exposed location it will be necessary to reduce the pipe pressure rating by 2% for each °C by which the ambient temperature exceeds 20° C.

## THERMAL MOVEMENT

Where the temperature of a uPVC pipeline is likely to vary due to atmospheric temperature it is important to plan the variations in pipeline length which may arise as a result of temperature differences.

Expansion and contraction can be calculated using the formula:

$$dL = \alpha \times L \times dt$$

Where dL = Change in the length in millimeters.

$\alpha$  = 0.08 mm/m/°C

L = Original length of pipe in meters.

dt = Total temperature range in °C

Calculations of expansion and contraction should take account of the minimum and maximum foreseeable temperature conditions.

When the total length variation of the pipeline has been established, the positioning of both support and anchor brackets can be determined.

Anchor brackets can be so arranged to sub-divide the total length variation and to control movement in a specific direction. Support brackets must allow the pipeline to move freely. It is normally possible with correct bracket arrangement to direct movement in such a manner that this is accommodated by directional changes in the line.

Expansion bellows may be used to accommodate excessive movement but in such instances the pipes so connected must be restrained against possible separation.

Any lines or valves must be firmly anchored and independently supported so that no stresses are transmitted to the pipeline.

# WATERMAIN uPVC PRESSURE PIPE

## PIPE BRACKETS

Standard or purpose-made metal pipe brackets are normally employed. These should be of the maximum possible bearing width and should have no sharp edges likely to cause pipe damage.

The brackets may be plastic coated but where this is not practical a layer of rubber felt or similar soft, non abrasive membranes must be fixed to the bearing face prior to installation.

## PIPE SUPPORT

uPVC pipes must be adequately supported. The following table shows the recommended support intervals for horizontal pipes conveying water.

Where liquids of greater density are being conveyed the intervals of support should be reduced proportionately.

For vertical pipe runs, the support intervals may be increased to double those shown except in exposed situations where wind loadings, etc, may dictate adherence to the intervals tabulated below.

## Pipe bracket spacing for PVC-U for liquids with a density of 1 g/cm<sup>3</sup>

d	DN	Pipe bracket intervals L for SDR21 / S 10 / PN10 pipes in mm at pipe wall temperature:				
		mm	inch	≤20 °C	30 °C	40 °C
16	3/8	950	900	850	750	600
20	1/2	1100	1050	1000	900	700
25	3/4	1200	1150	1050	950	750
32	1	1350	1300	1250	1100	900
40	1 1/4	1450	1400	1350	1250	1000
50	1 1/2	1600	1550	1500	1400	1150
63	2	1800	1750	1700	1550	1300
75	2 1/2	2000	1900	1850	1700	1450
90	3	2200	2100	2000	1850	1550
110	4	2400	2300	2250	2050	1750
125	-	2550	2450	2400	2200	1850
140	5	2700	2600	2500	2300	1950
160	6	2900	2800	2700	2500	2100
180	-	3100	2950	2850	2650	2200
200	-	3250	3150	3000	2800	2350
225	8	3450	3300	3200	2950	2500
250	-	3650	3500	3350	3100	2600
280	10	3750	3700	3550	3300	2750
315	12	4100	3900	3750	3500	2950
355	14	4300	4200	4000	3700	3100
400	16	4600	4450	4250	3950	3300

For other SDR multiply the values given in the table with the following factor:

SDR 13.6 / S 6.3 / PN16 with 1.08

SDR11 / S 5 / PN20 with 1.15

The pipe bracket spacing given in the table may be increased by 30 % in the case of vertical pipe runs, i. e. multiply the values given by 1.3.



# WATERMAIN uPVC PRESSURE PIPE

## TEMPERATURE CONVERSIONS

The number in the centre of the three columns will be converted from the FARENHEIT to CENTIGRADE by reading to the left and from CENTIGRADE to FARENHEIT by reading to the right.

			°C ←			→ °F					
-17.78	<b>0</b>	32.0	-1.11	<b>30</b>	86.0	15.56	<b>60</b>	140.0	32.2	<b>90</b>	194.0
-17.22	<b>1</b>	33.8	-0.56	<b>31</b>	87.8	16.1	<b>61</b>	141.8	32.8	<b>90</b>	195.8
-16.67	<b>2</b>	37.4	0	<b>32</b>	89.6	16.7	<b>62</b>	143.6	33.3	<b>92</b>	197.6
-16.11	<b>3</b>	37.4	0.56	<b>33</b>	91.4	17.2	<b>63</b>	145.4	33.9	<b>93</b>	199.4
-15.56	<b>4</b>	39.2	1.11	<b>34</b>	93.2	17.8	<b>64</b>	147.2	34.4	<b>94</b>	201.2
-15.00	<b>5</b>	41.0	1.67	<b>35</b>	95.0	18.3	<b>65</b>	149.0	35.0	<b>95</b>	203.0
-14.44	<b>6</b>	42.8	2.22	<b>36</b>	96.8	18.9	<b>66</b>	150.8	35.6	<b>96</b>	204.8
-13.89	<b>7</b>	44.6	2.78	<b>37</b>	98.6	19.4	<b>67</b>	152.6	36.1	<b>97</b>	206.6
-13.33	<b>8</b>	46.4	3.33	<b>38</b>	100.4	20.0	<b>68</b>	154.4	36.7	<b>98</b>	208.4
-12.78	<b>9</b>	48.2	3.89	<b>39</b>	102.2	20.6	<b>69</b>	156.2	37.2	<b>99</b>	210.2
-12.22	<b>10</b>	50.0	4.44	<b>40</b>	104.0	21.1	<b>70</b>	158.0	37.8	<b>100</b>	212.0
-11.67	<b>11</b>	51.8	5.00	<b>41</b>	105.8	21.7	<b>71</b>	159.8	40.6	<b>105</b>	221.0
-10.56	<b>12</b>	55.4	5.56	<b>42</b>	107.6	22.2	<b>72</b>	166.1	43.3	<b>110</b>	230.0
-11.11	<b>13</b>	53.6	6.11	<b>43</b>	109.4	22.8	<b>73</b>	163.4	46.1	<b>115</b>	239.0
-10.00	<b>14</b>	57.2	6.67	<b>44</b>	111.2	23.3	<b>74</b>	165.2	48.9	<b>120</b>	248.0
-9.44	<b>15</b>	59.0	7.22	<b>45</b>	113.0	23.9	<b>75</b>	167.0	51.7	<b>125</b>	257.0
-8.89	<b>16</b>	60.8	7.78	<b>46</b>	114.8	24.4	<b>76</b>	168.8	54.4	<b>130</b>	266.0
-8.33	<b>17</b>	62.6	8.33	<b>47</b>	116.6	25.0	<b>77</b>	170.6	57.2	<b>135</b>	275.0
-7.78	<b>18</b>	64.4	8.89	<b>48</b>	118.4	25.6	<b>78</b>	172.4	60.0	<b>140</b>	284.0
-7.22	<b>19</b>	66.2	9.44	<b>49</b>	120.2	26.1	<b>79</b>	174.2	62.8	<b>145</b>	293.0
-6.67	<b>20</b>	68.0	10.00	<b>50</b>	122.0	26.7	<b>80</b>	176.0	65.6	<b>150</b>	302.0
-6.11	<b>21</b>	69.8	10.56	<b>51</b>	123.8	27.2	<b>81</b>	177.8	68.3	<b>155</b>	311.0
-5.56	<b>22</b>	71.6	11.11	<b>52</b>	125.6	27.8	<b>82</b>	179.6	71.1	<b>160</b>	320.0
-5.00	<b>23</b>	73.4	11.67	<b>53</b>	127.4	28.3	<b>83</b>	181.4	73.9	<b>165</b>	329.0
-4.44	<b>24</b>	75.2	12.22	<b>54</b>	129.0	28.9	<b>84</b>	183.2	76.7	<b>170</b>	338.0
-3.89	<b>25</b>	77.0	12.78	<b>55</b>	131.0	29.4	<b>85</b>	185.0	79.4	<b>175</b>	347.0
-3.33	<b>26</b>	78.8	13.33	<b>56</b>	132.8	30.0	<b>86</b>	186.8	82.2	<b>180</b>	356.0
-2.78	<b>27</b>	80.6	13.89	<b>57</b>	134.6	30.6	<b>87</b>	188.6	85.0	<b>185</b>	365.0
-2.22	<b>28</b>	82.4	14.44	<b>58</b>	136.4	31.1	<b>88</b>	190.4	87.8	<b>190</b>	374.0
-1.67	<b>29</b>	84.2	15.00	<b>59</b>	138.2	31.7	<b>89</b>	192.2	90.6	<b>195</b>	383.0

## USEFUL EQUIVALENTS

BRITISH TO METRIC		METRIC TO BRITISH	
1 inch	= 25.4 millimetres	1 millimetre	= 0.0394 inch
1 foot	= 0.3048 metre	1 metre	= 3.28 feet
1 mile	= 1.609 kilometres	1 kilometre	= 0.6214 mile
1 square mile	= 2.59 km <sup>2</sup>	1 square kilometre	= 0.386 sq. mile
1 acre	= 0.4047 hectare	1 hectare = 10,000m <sup>2</sup>	= 2.471 acre
1 cubic foot	= 28.32 litres	1 cubic metre = 1000 litres	= 35.31 cubic feet
1 cubic yard	= 0.76 cubic metre		= 1.31 cubic yards
1 gallon	= 4.546 litres		= 219.97 gallons
1 pound	= 0.4536 kilogramme	1 kilogram	= 2.205 pounds
1 m.g.d	= 0.05261 m <sup>3</sup> /s	1 cubic metre per second	= 19.01 million gallons per day (m.g.d.)
1 lbf/per square inch	= 0.07031 kgf/cm <sup>2</sup>	1 kilogramme force per cm <sup>2</sup>	= 14.223 lbf per sq. inch
1 pound force (lbf)	= 4.448 newton (N)	1 kilo newton per m <sup>2</sup>	= 0.145 lbf/in <sup>2</sup>
1 lbf/in <sup>2</sup>	= 6.895 kN/m <sup>2</sup>	1 tonne = 1000 kg	= 0.984 U.K. tons
Acceleration due to gravity	= 9.807 m/s <sup>2</sup>	1 newton	= 0.2248 pound force
		1 bar = 29.530 in Hg	= 14.5038 lbf/in <sup>2</sup>

# WATERMAIN uPVC PRESSURE PIPE

## HYDROSTATIC TESTING

The length of test section will be determined by practical reasons such as availability of water, or the number of pipes, fittings and joints to be tested. Long pipelines should be tested in sections as mainlaying progresses.

The pipe length to be tested may be blanked off using a blank Iron or steel flange previously drilled and tapped for test equipment connection and strutted as necessary against end thrust. The blank flange may be attached to the pipeline by a Viking Johnson Flange Adaptor or similar.

Testing should preferably not be carried out against closed valves. All charging and testing should preferably be carried out from the lowest point of the under test section and all testing equipment should be located at this point. The pressure gauge also should be located at the lowest point or adjustment must be made for the level of the pressure gauge relative to the pipe's position.

Prior to testing, care should be taken to ensure that all anchor blocks have attained adequate maturity and that any solvent welded joints included in the pipe system have developed full strength. Correct support and anchorage of any above ground sections of the pipeline is also necessary. Underground pipelines should be backfilled, taking particular care to consolidate around lengths which may have been deflected to negative curves. All joints may be left exposed until testing is completed.

With the stand pipe, valves and pressure gauge assembled, filling of the main can begin.

The main should be charged slowly, preferably from the lowest point with any air cock in the "open" position. They should be closed in sequence from the lowest point only when water, visibly free from aeration, is being discharged through them. Satisfactorily charged, the main should be allowed to stand overnight to allow any residual air to "settle-out" and percolate to the pipe soffit. Re-venting is then necessary and any water deficiency should be made up.

Pressure testing can then begin by pumping slowly until the required test pressure is attained. A single or double cylinder hand pump should be used for this purpose. Mechanical pumps are not recommended unless incorporating a pre-set blow-off mechanism.

The hydrostatic testing specification will be at the discretion of the responsible engineer but should not exceed 1 ½ times the designed working pressure of the lowest rated component in the system and time duration of 24 hours.

A permissible water loss of 3 litres per kilometer of pipe per 25mm nominal bore, per 3 bar of test pressure, per 24 hours, may be considered reasonable.

Air testing is not recommended if, however, for practical reasons, pneumatic testing is necessary, this should be limited to a maximum pressure of 1.5 bar. Air leakage can be detected by applying soap solution to the joints or by pre-ordourising the air with Ethyl Mercaptan. This will reduce the time duration of an otherwise long-term pneumatic test.

During any air-pumping operations no one should be working on or near the test section and precautions should be taken to avoid heavy objects striking the main whilst under pneumatic pressure.

The foregoing notes provide a brief guide to the installation of PVC Water Mains and Services. The subject is dealt with in detail in British Standard Code of Practice CP312 Part 2 1973, available from the British Standards Institution.

# WATERMAIN uPVC PRESSURE PIPE

## INSPECTION AND TESTING

When the system has been fully installed all pipework and fittings should be visually inspected and hydraulically tested. Joints should be exposed until hydraulic testing has been successfully completed.

### VISUAL INSPECTION

The system should be visually inspected to ensure that the correct installation procedures have been followed and that the pipes and fittings are adequately supported and restrained in the prescribed manner.

### HYDRAULIC TESTING

The length of the section under test will be determined by practical considerations such as availability of water (000 metres of nominal diameter 12 pipe has a capacity of approximately 15,400 galls) and the number of joints or fittings to be tested.

#### a) Thrust forces

During installation the pipeline should have been suitably anchored to resist thrust at changes of direction and fixed points such as branches and hydrant connections. Testing should not take place until any un-situ concrete used as anchorage has matured and attained its required strength (normally a minimum of 7 days after placing).

Similarly solvent weld joints should be allowed to stand for a minimum of 24 hours before testing at 1 1/2 times working pressure is carried out. For lower test pressures allow one hour per 15 psi test pressure.

#### b) Charging the Mains

The test section should be isolated, where necessary, from the rest of the system. A blank end connection drilled and tapped for test equipment, will be required and should be installed on a suitable flange face. If no flange face is not available, the blank flange can be incorporated by means of a Viking Johnson Flange Adaptor or similar fitting.

Alternatively a suitable expanding stopper may be used. The blank flange or stopper and all the other blank ends on the system should be adequately strutted to resist the thrust developed as a result of the internal pressure (a nominal diameter 12 pipe with an internal pressure of 9 bar/ 130.5 psi will exert a thrust of 6.3 tons). **Testing should not be carried out against closed valves.**

The system should be filled from its lowest point with all air valves and control valves in the open position. Care should be taken to avoid pressure surges and to ensure that all air is expelled from the pipeline (the presence of air can seriously affect the results of pressure test operations). Air valves should be closed as filling proceeds when the air valves are seen to be discharging water free from aeration.

When fully charged, the system should be allowed to stand for a period of 24 hours with the air valves closed to allow any residual air to percolate to the pipe soffit. During this period the system can be visually examined for leakage. The system should then be revented and any water deficiency made up.

#### c) Pressurising

When charging is complete the pressure test equipment should be connected to the system via the blank flange or stopper. The equipment should consist of a single or double cylinder hand pump, a pressure gauge suitably graduated and preferably calibrated before use and press hoses to connect to a water supply and the blank flange or stopper.

The system should be pressurised slowly using the hand pump until the pressure gauge indicates the required value. The test pressure will be determined by the engineer responsible but should not exceed 1 1/2 times the nominal working pressure of the lowest rated component of the pipe system.

The duration of the test should be not less than one hour and not greater than 24 hours during which time the system should be isolated from the test pump.

### ASSESSMENT OF TEST

The test is assessed on the basis of the amount of water required to maintain the test pressure during the prescribed period. This amount of water should not exceed that calculated by the following formula:

2 Litres per kilometer of pipe, per metre of nominal bore per metre head of test pressure per 24 hours.

As specified in W.A.A. "Civil Engineering Specifications for the Water Industry"

For example, the permissible water loss for 1 kilometre to 6" diameter PN 12 pipe when tested at PN 18 (180 metres head) pressure would be  $2 \times 0.16 \times 1.0 \times 180 = 57.6$  litres per 24 hours or 2.4 litres per hour.

Any defects revealed during testing and any cause of failure to meet the prescribed requirements should be rectified and the system retested until a satisfactory result is obtained. It may be helpful to retest the mains in sections to assist in fault location.

# WATERMAIN uPVC PRESSURE PIPE

## PRESSURE EQUIVALENTS TABLE

Bar	ibf/in <sup>2</sup>	FEET HEAD	kg / cm <sup>2</sup>	METRES HEAD	Bar	ibf/in <sup>2</sup>	FEET HEAD	kg / cm <sup>2</sup>	METRES HEAD
0.1	1.45	3.35	0.10	1.02	7.6	110.23	254.26	7.75	77.50
0.2	2.90	6.69	0.20	2.04	7.7	111.68	257.61	7.85	78.52
0.3	4.35	10.04	0.31	3.06	7.8	113.13	260.95	7.95	79.54
0.4	5.80	13.38	0.41	4.08	7.9	114.58	264.30	8.06	80.56
0.5	7.25	16.73	0.51	5.10	8.0	116.03	267.64	8.16	81.58
0.6	8.70	20.07	0.61	6.12	8.1	117.48	270.99	8.26	82.60
0.7	10.15	23.42	0.71	7.22	8.2	118.93	274.33	8.36	83.62
0.8	11.60	26.76	0.82	8.16	8.3	120.38	277.68	8.46	84.64
0.9	13.05	30.11	0.92	9.18	8.4	121.83	281.03	8.57	85.66
1.0	14.50	33.46	1.02	10.20	8.5	123.28	284.37	8.67	86.68
1.1	15.95	36.80	1.12	11.22	8.6	124.73	287.72	8.77	87.70
1.2	17.40	40.15	1.22	12.24	8.7	126.18	291.06	8.87	88.72
1.3	18.86	43.49	1.33	13.26	8.8	127.63	294.41	8.97	89.74
1.4	20.31	46.84	1.43	14.82	8.9	129.08	297.75	9.08	90.76
1.5	21.76	50.18	1.53	15.30	9.0	130.53	301.10	9.18	91.78
1.6	23.21	53.53	1.63	16.35	9.1	131.98	304.44	9.28	92.79
1.7	24.66	56.87	1.73	17.34	9.2	133.43	307.79	9.38	93.81
1.8	26.11	60.22	1.84	18.36	9.3	134.89	311.14	9.48	94.83
1.9	27.56	63.57	1.94	19.37	9.4	136.34	314.48	9.59	95.85
2.0	29.01	66.91	2.04	20.39	9.5	137.79	317.83	9.69	96.87
2.1	30.46	70.26	2.14	21.41	9.6	139.24	321.17	9.79	97.89
2.2	31.91	73.60	2.24	22.43	9.7	140.69	324.52	9.89	98.91
2.3	33.36	76.95	2.35	23.45	9.8	142.14	327.86	9.99	99.93
2.4	34.81	80.29	2.45	24.47	9.9	143.59	331.21	10.10	100.95
2.5	36.26	83.64	2.55	25.49	10.0	145.04	334.55	10.20	101.97
2.6	37.71	86.98	2.65	26.51	10.1	146.49	337.90	10.30	102.99
2.7	39.16	90.33	2.75	27.53	10.2	147.94	341.25	10.40	104.01
2.8	40.61	93.68	2.86	28.55	10.3	149.39	344.59	10.50	105.03
2.9	42.06	97.02	2.96	29.57	10.4	150.84	347.94	10.61	106.05
3.0	43.51	100.37	3.06	30.59	10.5	152.29	351.28	10.71	107.07
3.1	44.96	103.71	3.16	31.61	10.6	153.74	354.63	10.81	108.09
3.2	46.41	107.06	3.26	32.63	10.7	155.19	357.97	10.91	109.11
3.3	47.86	110.40	3.37	33.65	10.8	156.64	361.32	11.01	110.13
3.4	49.31	113.75	3.47	34.67	10.9	158.09	364.66	11.12	111.15
3.5	50.76	117.09	3.57	35.69	11.0	159.54	368.01	11.22	112.17
3.6	52.21	120.44	3.67	36.71	11.1	160.99	371.36	11.32	113.19
3.7	53.66	123.79	3.77	37.73	11.2	162.44	374.70	11.42	114.21
3.8	55.11	127.13	3.88	38.75	11.3	163.89	378.05	11.52	115.23
3.9	56.56	130.48	3.98	39.77	11.4	165.34	381.39	11.63	116.25
4.0	58.02	133.82	4.08	40.79	11.5	166.79	384.74	11.73	117.27
4.1	59.47	137.17	4.18	41.81	11.6	168.24	388.08	11.83	118.29
4.2	60.92	140.51	4.28	42.83	11.7	169.69	391.43	11.93	119.31
4.3	62.37	143.86	4.38	43.85	11.8	171.14	394.77	12.03	120.33
4.4	63.82	147.20	4.49	44.87	11.9	172.60	398.12	12.14	121.35
4.5	65.27	150.55	4.59	45.89	12.0	174.05	401.47	12.24	122.37
4.6	66.72	153.90	4.69	46.91	12.1	175.50	404.81	12.34	123.39
4.7	68.17	157.24	4.79	47.93	12.2	176.95	408.16	12.44	124.41
4.8	69.62	160.59	4.89	48.95	12.3	178.40	411.50	12.54	125.43
4.9	71.07	163.93	5.00	49.97	12.4	179.85	414.85	12.65	126.45
5.0	72.52	167.28	5.10	50.99	12.5	181.30	417.91	12.75	127.47
5.1	73.97	170.62	5.20	52.01	12.6	182.75	421.54	12.85	128.49
5.2	75.42	173.97	5.30	53.03	12.7	184.20	424.88	12.95	129.50
5.3	76.87	177.31	5.40	54.05	12.8	185.65	428.23	13.05	130.52
5.4	78.32	180.66	5.51	55.07	12.9	187.10	431.58	13.15	131.54
5.5	79.77	184.01	5.61	56.08	13.0	188.55	434.92	13.26	132.56
5.6	81.22	187.35	5.71	57.10	13.1	190.00	438.27	13.36	133.58
5.7	82.67	190.70	5.81	58.12	13.2	191.45	441.61	13.46	134.60
5.8	84.12	194.04	5.91	59.14	13.3	192.90	444.96	13.56	135.62
5.9	85.57	197.39	6.02	60.16	13.4	194.35	448.30	13.66	136.64
6.0	87.02	200.73	6.12	61.18	13.5	195.80	451.65	13.77	137.66
6.1	88.47	204.08	6.22	62.20	13.6	197.25	455.00	13.87	138.68
6.2	89.92	207.42	6.32	63.22	13.7	198.70	458.34	13.97	139.70
6.3	91.37	210.77	6.42	64.24	13.8	200.15	461.69	14.07	140.72
6.4	92.82	214.12	6.53	65.26	13.9	201.60	465.03	14.17	141.74
6.5	94.27	217.46	6.63	66.28	14.0	203.05	468.38	14.28	142.76
6.6	95.73	220.81	6.73	67.30	14.1	204.50	471.72	14.38	143.78
6.7	97.18	224.15	6.83	68.32	14.2	205.95	475.07	14.48	144.80
6.8	98.63	227.50	6.93	69.34	14.3	207.40	478.41	14.58	145.82
6.9	100.08	230.84	7.04	70.36	14.4	208.85	481.76	14.68	146.84
7.0	101.53	234.19	7.14	71.38	14.5	210.31	485.10	14.79	147.86
7.1	102.98	237.53	7.24	72.40	14.6	211.76	488.45	14.89	148.88
7.2	104.43	240.88	7.34	73.42	14.7	213.21	491.80	15.00	149.90
7.3	105.88	244.23	7.44	74.44	14.8	214.66	495.14	15.09	150.92
7.4	107.33	247.57	7.55	75.46	14.9	216.11	498.49	15.19	151.94
7.5	108.78	250.92	7.65	76.48	15.0	217.56	501.83	15.30	152.96



# WATERMAIN uPVC PRESSURE PIPE

## MATERIAL PROPERTIES OF uPVC

uPVC pipes and fittings exhibit excellent resistance to aggressive environments, both naturally occurring and as a result of industrial activity.

### RESISTANCE TO CORROSION

uPVC pipes and fittings are resistant to almost all types of corrosion, whether chemical or electro-chemical in nature. Since uPVC is a non-conductor, galvanic and electro-chemical effects do not occur in uPVC pipe systems.

Because it is non metallic, the material is totally resistant to all forms of metallic corrosion. Aggressive waters resulting from both high sulphate soils and low hardness waters will not attack uPVC in any way.

uPVC pipes and fittings can also be considered resistant to a wide range of industrial waters and chemicals and can offer advantages in long term system life and maintenance costs.

### CHEMICAL RESISTANCE

The resistance uPVC pipes and fittings to the chemical agents listed below has been drawn from CP312: Part 1: 1973 'General Principles and Choice of Materials'.

Ratings for the EPDM seals used in the Watermain System have been included, where the uPVC rating differs from the EPDM rating or where further information on chemicals not listed here is required, refer to the Hepworth Technical Department.

## CHEMICAL RESISTANCE TABLE

### uPVC PIPE, FITTINGS AND E.P.D.M SEALS

MEDIUM (NAME)	CONCENTRATION	RATING @ 20°C	
		PVC-U	EPDM
Acetaldehyde	technically pure 40% aqueous solution	— ○	+ ○
Acetic Acid	technically pure glacial 40% aqueous 10% aqueous	○ ○ +	+ ○ +
Acetic Acid Anhydride	technically pure	—	+
Acetone	technically pure up to 10% aqueous	— —	+ ○
Acrylic Ester	technically pure	—	○
Acrylonitrile	technically pure	—	○
Adipic Acid	technically aqueous	+	+
Alcoholic Spirits (gin, whisky etc.)	(approx 40% Ethyl Alcohol)	+	○
Aluminium Chloride	10% aqueous saturates	+ +	+ +
Aluminium Sulphate	10% aqueous cold saturates aqueous	+ +	+ +
Ammonia	gaseous technically pure	+	+
Ammonium Acetate	aqueous all	+	C
Ammonium Carbonate	50% aqueous	+	+
Ammonium Chloride	aqueous 10% aqueous cold saturated	+ +	+ +
Ammonium Hydrogen Fluoride	50% aqueous	+	+
Ammonium Hydroxide	aqueous cold saturated	+	+

MEDIUM (NAME)	CONCENTRATION	RATING @ 20°C	
		PVC-U	EPDM
Ammonium Nitrate	technically pure 40% aqueous solution	+ +	+ +
Ammonium Phosphate	aqueous all	+	+
Ammonium Sulphate	10% aqueous aqueous saturated	+ +	+ +
Ammonium Sulphide	aqueous all	+	+
Amyl Acetate	technically pure	—	+
Amyl Alcohol	technically pure	+	+
Aniline	technically pure	—	○
Aniline Hydrochloride	aqueous saturated	+	○
Antimony Trichloride	90% aqueous	+	+
Aqua Regia		+	C
Arsenic Acid	80% aqueous	+	+
Barium Hydroxide	aqueous saturated	+	+
Barium Salts	aqueous all	+	C
Beef Tallow Emulsion			
Sulphonated	usual commercial	+	C
Beer	usual commercial	+	+
Benzaldehyde	saturated aqueous	—	+
Benzene	technically pure	+	C
Benzine	Free of lead and aromatic compounds	+	C
Benzoic Acid	all aqueous	+	+

KEY + Recommended ○ Recommended  
— Not Recommended C Not Recommended

# WATERMAIN uPVC PRESSURE PIPE

## CHEMICAL RESISTANCE TABLE

### UPVC PIPE, FITTINGS AND E.P.D.M SEALS

MEDIUM (NAME)	CONCENTRATION	RATING @ 20°C	
		PVC-U	EPDM
Benzyl Alcohol	technically pure	0	0
Bleaching Dye	12.5% active chlorine aqueous	+	+
Borax	all aqueous	+	+
Boric Acid	all aqueous	+	+
Brandy	usual commercial	+	+
Brine, Sea Water		+	+
Bromine Liquid	technically pure	—	C
Bromine Vapours	high	—	C
Bromine Water	saturated aqueous	+	C
Butadiene	technically pure	+	C
Butane	technically pure	+	C
Butanol	technically pure	+	
Butyl Acetate	technically pure	—	
Butyl phenol	technically pure	0	C
Butylene Glycol	technically pure	+	
Butylene Liquid	technically pure	+	C
Butynediol	aqueous 10%	+	C
Butyric Acid	technically pure	+	C
Calcium Chloride	saturated aqueous all	+	+
Calcium Hydroxide	aqueous saturated	+	+
Calcium Hypochloride	cold saturated aqueous	+	+
Calcium Nitrate	50% aqueous	+	+
Carbon Dioxide (carbonic acid)	technically pure anhydrous	+	+
	technically pure moist	+	+
Carbon Disulphide	technically pure	—	C
Carbon Tetrachloride	technically pure	—	—
Caustic Potash Solution	50% aqueous	+	+
Caustic Soda Solution	up to 10% aqueous	+	+
	up to 40% aqueous	+	+
	50% aqueous	+	+
Caustrial Hydrate	technically pure	—	C
Chorethanol	technically pure	—	C
Chloric Acid	10% aqueous	+	C
	20% aqueous	+	C
Chlorine	moist 90% gaseous	0	+
	anhydrous tech.pure	0	+
	liquid, tech.pure	—	0
Chlorine Water	saturated	0	0
Chloroacetic Acid Mono	technically pure	+	+
	50% aqueous	+	+
Chlorobenzene	technically pure	—	C
Chloroform	technically pure	—	—
Chloro methane (methyl chloride)	technically pure	—	—
Chlorosulphonic Acid	technically pure	0	C
Chrome Alum	cold saturated aqueous	+	+
Chromic Acid	up to 50% aqueous	+	C
	all aqueous	+	C
Chromic Acid + Sulphuric Acid + Water	50 g 15 g 35 g	+	C

MEDIUM (NAME)	CONCENTRATION	RATING @ 20°C	
		PVC-U	EPDM
Cider		+	+
Citric Acid	10% aqueous	+	+
Clophenes	technically pure	—	C
Coal Gas (benzene free)		+	C
Coconut Fat Alcohol	technically pure	+	C
Coconut Oil	technically pure	+	+
Compressed Air			
Containing Oil		0	0
Copper Salts	all aqueous	+	+
Corn Oil	technically pure	0	C
Cresol	up to 90%aqueous	0	C
Crotonic Aldehyde	technically pure	—	C
Cyclohexane	technically pure	—	—
Cyclohexanol	technically pure	+	+
Cyclohexanone	technically pure	—	0
Densodrine W		+	C
Detergents	for usual washing lathers	+	+
Dextrine (starch gum)	usual commercial	+	C
Dibutyl Ether	technically pure	—	—
Dibutyl Phthalate	technically pure	—	+
Dibutyl Sebacate	technically pure	—	—
Dichloroacetic Acid	technically pure	+	+
	50% aqueous	+	+
Dichlorobenzene	technically pure	—	—
Dichlorethylene	technically pure	—	—
Diesel Oil		+	+
Diethylamine	technically pure	0	C
Diglycolic Acid	30% aqueous	+	+
Di-isobutyl Ketone	technically pure	—	C
Dimethyl Formamide	technically pure	—	0
Dimethylamine	technically pure	0	—
Dinonyl Phthalate	technically pure	—	—
Diocetyl Phthalate	technically pure	—	
Dioxone	technically pure	—	+
Ethyl Acetate	technically pure	—	+
Ethyl Alcohol	technically pure 96%	+	+
Ethyl Alcohol + Acetic Acid		+	+
Ethyl Benzene	technically pure	—	—
Ethyl Chloride	technically pure	—	+
Ethyl Ether	technically pure	—	0
Ethylene Chloride	technically pure	—	C
Ethylene Diamine	technically pure	0	C
Ethylene Glycol	technically pure	+	+
Ethylene Oxide	technically pure liquid	—	C
Fatty Acids	technically pure	+	+
Fatty Alcohol Sulphonates	aqueous	+	+
Fertilizer Salts	aqueous	+	+
Flourine	technically pure	0	0
Floulsilicic Acid	32% aqueous	+	+
Formaldehyde (formalin)	40% aqueous	+	+
Formamide	technically pure	—	C

KEY + Recommended 0 Conditionally Recommended  
 — Not Recommended C Consult Hepworth Tech. Service Dept.

# WATERMAIN uPVC PRESSURE PIPE

## CHEMICAL RESISTANCE TABLE

### uPVC PIPE, FITTINGS AND E.P.D.M SEALS

MEDIUM (NAME)	CONCENTRATION	RATING @ 20 °C	
		PVC-U	EPDM
Formic Acid	up to 50% aqueous	+	+
	technically pure	+	+
Frigen 12 (freon 12)	technically pure	+	+
Fruit Juices		+	+
Fruit Pulp		+	+
Fuel Oil		+	C
Furfury Alcohol	technically pure		
Gelatine	all aqueous	+	+
Glucose	all aqueous	+	+
Glycerine	technically pure	+	+
	all aqueous	+	+
Glycocol (glycin)	10% aqueous	+	C
Glycolic Acid	37% aqueous	+	O
Heptane	technically pure	+	C
Hexane	technically pure	+	C
Hydrazine Hydrate	aqueous	+	C
Hydrobromic Acid	aqueous 50%	+	+
Hydrochloric Acid	5% aqueous	+	+
	10% aqueous	+	+
	up to 30% aqueous	+	+
	36% aqueous	+	+
Hydrocyanic Acid	technically pure	+	+
Hydrofluoric Acid	70% aqueous	+	O
	50% aqueous	+	O
	up to 40% aqueous		O
Hydrogen	technically pure	+	+
Hydrogen Chloride	technically pure	+	C
	gaseous		
Hydrogen Peroxide	10% aqueous	+	C
	30% aqueous	+	C
Hydrogen Sulphide	technically pure	+	+
	saturated aqueous	+	+
Hydroxylamine Sulphate	all aqueous	+	C
Iodine Solution	65% iodine in ethanol	—	O
Iron Salts	all aqueous	+	+
Iso-octane	technically pure	+	+
Isoprophyl Alcohol	technically pure	+	+
Isoprophyl Ether	technically pure	—	C
Lactic Acid	10% aqueous	+	+
Lanolin	technically pure	+	C
Lead Acetate	aqueous saturated	+	+
Linseed Oil	technically pure	+	C
Liquers		+	C
Lubricating Oils		+	C
Lubricating Oils free of aromatic compounds		+	C
Magnesium salts	all aqueous	+	+
Maleic Acid	cold saturated aqueous	+	C
Malic Acid	1% aqueous	+	C
Marmalade		+	+
Mercury	pure	+	+
Mercury Salts	cold saturated aqueous	+	+
Methane	technically pure	+	C
Methanol	all	+	+

MEDIUM (NAME)	CONCENTRATION	RATING @ 20 °C	
		PVC-U	EPDM
Methyl Acetate	technically pure	—	C
Methyl Amine	32% aqueous	O	C
Methyl Bromide	technically pure	—	C
Methyl Chloride	technically pure	—	C
Methyl Ethyl Ketone	technically pure	—	+
Methyl Chloride	technically pure	—	C
Milk		+	+
Mineral Water		+	+
Mixed Acids (i)			
Sulphuric	48% ]		
Nitric	49% ]	+	+
Water	3% ]		
	50% ]		
	31% ]	+	+
	19% ]		
	10% ]		
	20% ]	+	+
	70% ]		
Mixed Acids (ii)			
Nitric	3parts	O	O
Hydrofluoric	1 part		
Sulphuric	2 parts		
Mixed Acids (iii)			
Sulphuric	30%	+	+
Phosphoric	60%		
Water	10%		
Molasses		+	+
Molasses Wort		+	+
Monochloroacetic Acid Ethyl Ester	technically pure	O	C
Monochloroacetic Acid Methyl Ester	technically pure	O	C
Morphalin	technically pure	—	C
Mowilith D	usual commercial	+	C
Naphthalene	technically pure	—	C
Nickel Salts	cold saturated aqueous	+	+
Nitric Acid	6.3% aqueous	+	+
	up to 40% aqueous	+	+
	65% aqueous	O	O
	100%	—	C
Nitrobenzene	technically pure	—	C
Nitrotoluene	technically pure	O	C
Nitrous Gases	low, wet & dry	+	C
Oleic Acid	technically pure	+	O
Oleum	10% SO <sub>3</sub>	+	C
Oleum Vapours	traces	+	C
Olive Oil		+	C
Oxalic Acid	cold saturated aqueous	+	+
Oxygen	all	+	+
Ozone	up to 2% in air	+	+
	cold saturated aqueous	+	+
Palm Oil, Palm Net Oil		+	C
Palmitic Acid	technically pure	+	C
Paraffin Emulsions	usual commercial aqueous	+	C
Paraffin Oil		+	C
Perchloric Acid	10% aqueous	+	C
	70% aqueous	O	C

KEY + Recommended O Conditionally Recommended  
 - Not Recommended C Consult Hepworth Tech. Service Dept.

# WATERMAIN uPVC PRESSURE PIPE

## CHEMICAL RESISTANCE TABLE

### uPVC PIPE, FITTINGS AND E.P.D.M SEALS

MEDIUM (NAME)	CONCENTRATION	RATING @ 20°C	
		PVC-U	EPDM
Perchloroethylene	technically pure	—	C
Petroleum	technically pure	+	C
petroleum Ether	technically pure	+	C
Petroleum Jelly	technically pure	0	C
Phenol (carbolic acid)	up to 10% aqueous	+	C
	up to 90% aqueous	0	C
Phenylhydrazine	technically pure	—	C
Phenylhydrazine Hydrochloride	aqueous	0	C
Phosgene	liquid technically pure	—	C
	gaseous technically pure	+	C
Phosphoric Acid	up to 30% aqueous	+	C
	50% aqueous	+	C
	85% aqueous	+	C
Phosphorous Chlorides		—	—
Phosphorous Trichlorides		C	C
Phosphorous Pentachloride		C	C
PhosphorousOxychloride	technically pure	—	+
Phosphorous Pentoxide	technically pure	+	C
Photographic Developer	usual commercial	+	C
Photographic Emulsion		+	C
Photographic Fixer	usual commercial	+	C
Phthalic Acid	saturated aqueous	+	C
Picric Acid	1% aqueous	+	C
Potash (potassium carbonate)	cold saturated aqueous	+	+
Pottassium/ Aluminium Sulphates (Alum)	50% aqueous	+	+
Pottassium Bichromate	saturated aqueous	+	+
Pottassium Borate	10% aqueous	+	+
Pottassium Bromate	cold saturated aqueous	+	+
pottassium Bromide	all aqueous	+	+
pottassium Chloride	cold saturated aqueous	+	+
Pottassium Chloride	all aqueous	+	+
pottassium Chromate	cold saturated aqueous	+	+
Pottassium Cyanide	cold saturated aqueous	+	+
Pottassium Iodide	cold saturated aqueous	+	+
Pottassium Nitrate (saltpetre)	50% aqueous	+	+
Pottassium Perchlorate	cold saturated aqueous		C
Pottassium Permanganate	cold saturated aqueous	+	C
Pottassium Persulphate	all aqueous	+	+
Pottassium Phosphates	all aqueous	+	+
Pottassium Sulphate	all aqueous	+	+
Propane	technically pure, liquid	+	C
	technically pure, gaseous	+	C
Propanol	technically pure	+	+
Propargyl Alcohol	7% aqueous	+	C
Propionic Acid	50% aqueous	+	C
	technically pure	+	C
Propylene Glycol	technically pure	+	+
Propylene Oxide	technically pure	0	C
Pyridine	technically pure	—	C
Ramasit fabric water proofing agents	usual commercial	+	+

MEDIUM (NAME)	CONCENTRATION	RATING @ 20°C	
		PVC-U	EPDM
Silicon Oil		+	C
Silver Salts	cold saturated aqueous	+	+
Soap Solution	all aqueous	+	+
Sosium Acetate	all aqueous	+	+
Sodium Benzoate	cold saturated aqueous	+	+
Sodium Bicarbonate	cold saturated aqueous	+	+
Sodium Bisulphate	10% aqueous	+	+
Sodium Bisulphite	all aqueous	+	+
Sodium Bromate	all aqueous	+	C
Sodium Bromide	all aqueous	+	+
Sodium Carbonate (soda)	cold saturated aqueous	+	+
Sodium Chlorate	all aqueous	+	+
Sodium Chloride	all aqueous	+	+
Sodium Chloride	up to 10% aqueous	0	+
Sodium Chromate	up to 10% aqueous	+	C
Sodium Disulphite	all aqueous	+	C
Sodium Dithionite (hydrosulphite)	up to 10% aqueous	+	C
Sodium Fluoride	cold saturated aqueous	+	+
Sodium Hypochloride	12.5% aactive chlorine aqueous	+	C
Sodium Iodine	all aqueous	+	C
Sodium Nitrate	cold saturated aqueous	+	+
Sodium Nitrate	cold saturated aqueous	+	+
Sodium Oxalate	cold saturated aqueous	+	C
Sodium Persulphate	cold saturated aqueous	+	C
Sodium Phosphate	cold saturated aqueous	+	+
Sodium Silicate	cold saturated aqueous	+	+
Sodium Sulphate	cold saturated aqueous	+	+
Sodium Sulphide	cold saturated aqueous	+	+
Sodium Thiosulphate	cold saturated aqueous	+	+
Spindle Oil		0	C
Spinning Bath Acids containing Carbon Disulphide	100mg CS 2/1	+	C
Stannous Chloride	cold saturated aqueous	+	C
Starch Solution	all aqueous	+	+
Starch Syrup	usual commercial	+	C
Stearic Acid	technically pure	+	C
Succinic Acid	all aqueous	+	C
Sugar Syrup	usual commercial	+	C
Sulphur	technically pure	0	+
Sulphur Dioxide	technically pure anhydrous	+	+
	all moist	+	+
	technically pure liquid	—	+
Sulphur Trioxide		—	C
Sulphuric Acid	up to 40% aqueous	+	+
	up to 60% aqueous	+	+
	up to 80% aqueous	+	+
	90% aqueous	+	+
	96% aqueous	+	+
Sulphurous Acid	saturated aqueous	+	C
Sulphuric Chloride	technically pure	—	C

KEY + Recommended 0 Conditionally Recommended  
 — Not Recommended C Consult Hepworth Tech. Service Dept.



# WATERMAIN uPVC PRESSURE PIPE

## CHEMICAL RESISTANCE TABLE

### uPVC PIPE, FITTINGS AND E.P.D.M SEALS

MEDIUM (NAME)	CONCENTRATION	RATING @ 20°C	
		PVC-U	EPDM
Tallow	technically pure	+	C
Tannic Acid	all aqueous	+	+
Tanning Extracts from plants	usual	+	C
Tartaric Acid	all aqueous	+	C
Tetrachloroethane	technically pure	—	C
Tetraethyl Lead	technically pure	+	C
Tetrahydrofurane	technically pure	—	O
Tetrahydronaphtalene (tetralin)	technically pure	—	C
Thionyl Chloride	technically pure	—	C
Toluene	technically pure	—	C
Thionylphosphate	technically pure	—	+
Trichloroethane	technically pure	—	C
Trichloroacetic Acid	technically pure	O	O
	50% aqueous	+	O
Trichloroethane	technically pure	—	C
Tricresyl Phosphate	technically pure	—	+
Triethanolamine	technically pure	O	C
Troctyl Phosphate	technically pure	—	C
Turpentine Oil	technically pure	+	C
Urea	up to 30% aqueous	+	C
Urine		+	+
Vegaetable Oils & Fats		+	+
Vinegar	usual commercial	+	+

KEY + Recommended 0 Conditionally Recommended  
 - Not Recommended C Consult Hepworth Tech. Service Dept.

MEDIUM (NAME)	CONCENTRATION	RATING @ 20°C	
		PVC-U	EPDM
Vinyl Acetate	technically pure	—	+
Vinyl Chloride	technically pure	—	+
Viscose Spinning Solution		+	C
Waste Gases	all	+	+
Containing carbon dioxide		+	+
Carbon Monoxide	all	+	+
Hydrochloric Acid	all	+	+
Hydrogen Flouride	traces	+	+
Nitrous Gases	traces	+	+
Sulphur Dioxide	traces	+	+
Sulphur Trioxide	traces	+	+
Sulphuric Acid	all	+	+
Water	condensed	+	+
Water	distilled deionised	+	+
Water	drinking	+	+
Water	waste without organic solvent	+	+
Wax Alcohol	technically pure	+	+
Wetting Agents	up to 5% aqueous	+	+
Wines (red & white)	usual commercial	+	+
Wine Vinegar	usual commercial	+	+
Yeast	all aqueous	+	+
Yeast Wort	working concentration	+	+
Xylene	technically pure	—	C
Zinc Salts	all aqueous	+	+

# WATERMAIN uPVC PRESSURE PIPE

## GENERAL GUIDANCE NOTES

### RESISTANCE TO BIOLOGICAL ATTACK/GROWTH

uPVC pipes and fittings will not deteriorate under attack from bacteria or other microorganisms and will not provide a food source to microorganisms, macro-organisms and fungi.

Recent research has shown that certain elastomeric sealing rubbers can be susceptible to the support of microbiological growth. The water industry has specified that elastomers for use as sealing rings in potable water pipes should not be capable of supporting microbiological growth.

The Watermain Triple Seal is manufactured from EPDM (Ethylene Propylene Diene Monomer), which has been listed by the United Kingdom Water Fitting Bylaws Scheme for use with potable water.

The Watermain lubricant has been similarly tested and approved for use with potable water.

### RESISTANCE TO WEATHERING

It is well known that thermoplastic materials may be affected by prolonged exposure to high levels of solar radiation. Exposure to sunlight for prolonged periods has two effects on uPVC pipes and fittings.

a) Surface Degradation: caused by high levels of ultra violet radiation, which manifests itself as discolouration and crazing of the surface of the uPVC.

b) Solar Gain: surface temperature of the uPVC pipes and fittings can reach as high as 16°C above the ambient temperatures in areas such as the Middle East.

Surface degradation of uPVC pipes and fittings causes a slight deterioration in the impact properties in addition to the colour changes. To protect the uPVC pipes from UV degradation, two coats of Emulsion type paint (water based), preferably white colour applied to the pipe work. All pipes and fittings must be cleaned and de-greased with pipe cleaner and the surface should be roughened slightly with fine emery paper, to allow paint to adhere.

However, research has shown that this and other properties such as hydrostatic burst strength, tensile strength and resistance to negative pressure are still above the British Standard requirements even after prolonged periods of exposure.

Solar gain due to exposure to direct or indirect sunlight can raise the surface temperature of pipes and fittings and this can lead to problems of ovalisation and longitudinal bending during storage.

However these effects can be avoided if the pipes and fittings are properly stored. Please refer to page 33/34 for recommendations on storage and handling.

### RESISTANCE TO ABRASION & TUBERCULATION

uPVC pipes have excellent abrasion resistance properties. The nature of uPVC is such that the material gradually erodes over a large area, localized pitting does not occur.

Comparisons are difficult because of the variations occurring according to the abrasive fluid and number of cycles.

However, in tests using the same percentage concentration and duration time, uPVC pipes exhibited an abrasive resistance some 2.5 times greater than mild steel.

uPVC pipe is not subject to the effects of tuberculation caused by corrosion by-products. Soluble encrustants, such as calcium carbonate, do not precipitate onto the walls of uPVC pipes.

### INSITU BENDING

#### GENERAL

One of the practical features of uPVC pipes is their ability to bend when cold. The benefits of this cold bending property can be utilized during installation and when the pipe is in service.

During installation pipes can be cold bent as a means of overcoming certain topographical or man-made obstructions without recourse to the use of purpose made bends.

During service the pipe has an inbuilt ability to take up ground movements caused by subsidence or differential settlement without undue stresses being incurred in the pipe wall.

#### PRACTICAL CONSIDERATIONS

It can be shown that as the pipe diameter increases the force required to affect the bending radius quoted increases.

The force required can place practical limitations on the maximum pipe diameter considered suitable for bending during installation. CP312: part 2: 1973 refers to a limiting size of nominal diameter 6.

For larger diameters the decision to attempt cold bending will depend upon available resources, site conditions and ambient temperatures. The following points must be considered in all cases: -

- (a) Cold bending should not be attempted at ambient temperatures less than 5°C
- (b) The trailing socket must be securely fixed in position before the pipe is bent.
- (c) On no account must the trailing socket be subject to angular deflection and hence additional stresses.
- (d) Bending should be carried out manually wherever possible.
- (e) If mechanical pulling devices are used the pipe must be adequately protected from damage. Metal chains, slings, hooks or straps must not come into direct contact with the pipe.

# WATERMAIN uPVC PRESSURE PIPE

## GENERAL GUIDANCE NOTES

(f) The pipe must be securely fixed in its radiused position before laying proceeds. uPVC pipe has a “memory” and will restraighten itself if it is not secured.

(g) Every precaution shall be taken during the drawing operation to ensure the safety of site personnel.

### EXPANSION AND CONTRACTION

In common with a number of engineering materials unplasticized PVC will expand and/or contract under the influence of various in pipe and ambient temperatures. The Coefficient of Thermal Expansion/Contraction of uPVC pipes which is equal to  $6.0 \times 10^{-5}$  per C is relatively high compared with another materials. Due count should be taken of possible expansion or contraction when installing uPVC pipes which will be subjected to variations in temperature either immediately following installation or in their service life time.

### EXPANSION AND CONTRACTION ALLOWANCE

The length by which a particular length of uPVC pipe will expand or contract under a given variation in temperature is given by:

$$\delta L = \alpha \times \text{Ø} \times \delta T$$

where  $\delta L$  = change in length in millimetres  
 $\alpha$  = the coefficient of linex expansion  
 $L$  = the length of PVC-U pipe under consideration  
 $\delta T$  = the variation in temperature

If the installation is made up of pipes with Loc Ring Integral Sockets the expansion/contraction can normally be accommodated within the socket without recourse to special fittings or pipe arrangements.

In above ground installations the solvent weld jointing system is normally adopted and in this case special provisions will need to be made to accommodate movement resulting from expansion or contraction.

Please consult our Technical Department in these cases.

### EXTERNAL COMPRESSIVE LOADS

#### SOIL AND TRAFFIC LOADS

Under normal operating conditions it is not necessary to confirm the performance of a uPVC pressure pipe for resistance to soil and traffic loadings.

In these conditions the stress resulting from the internal pressure greatly outweighs the soil and traffic load stresses.

However, in certain circumstances where mains are expected to stand empty for long periods of time, engineers may wish to confirm the structural capabilities of the pipe system under soil and traffic load conditions.

Please consult the Hepworth Technical Department for further information.

### THRUST RESTRAINT

A uPVC pipeline operating under internal pressure will generate thrust forces at any change of direction, reduction in diameter, blank end or closed valve.

Allowance should be made to accommodate the thrust forces developed which would otherwise cause deflection, extension or joint separation in the pipeline.

It is most important that the thrust forces are calculated using the maximum internal pressure to which the pipeline is likely to be subjected.

This in the majority of cases, is the site inspection test pressure (usually  $1 \frac{1}{2}$  times the working pressure).

In above ground installations purpose made struts or fixed brackets will be required to design resist the developed thrust modified by an appropriate factor of safety.

In below ground installation the normal method used for thrust resistance is to construct an anchor block at the point at which the thrust is developed.

The purpose of the anchor block is to transfer the thrust load to the surrounding ground and the decision on load bearing capabilities of the ground must be made at the design stage.

This will depend on the nature of the surrounding ground and will determine the dimensions of the thrust block required to resist the calculated thrust force.

When partially or completely surrounding uPVC pipes or fittings in concrete the pipe or fitting should be wrapped in heavy gauge polyethylene sheet which allow the pipe to decent slightly under the action of internal pressure and avoid stress concentration at the rigid/flexible interface.

### PIPE SUPPORT

In many non-buried situations the need arise to provide pipe supports to ensure that the weight of the pipe and it's contents are adequately supported.

The recommended maximum support spacing given are for uPVC pressure pipes operating under the following conditions:-

1. Contents density 1 g/cc
2. Operating pressure PN 9
3. Horizontal pipe runs

# WATERMAIN uPVC PRESSURE PIPE

## HANDLING, TRANSPORT AND STORAGE

Watermain pipes and fittings are manufactured from uPVC, a material approximately one fifth the weight of ductile iron. Pipes and fittings made from this material are therefore light in weight and there may be a tendency to employ improper handling techniques which result in damage to the pipes and fittings. Reasonable care should be taken in the handling and transport which should be undertaken according to the following recommendations.

### HANDLING

a) Pipes should not be dropped onto hard surfaces and should not be dragged along the ground. This is particularly important where the pipe ends have been prepared in the form of spigots (eg. chamfered ends) and integral sockets.

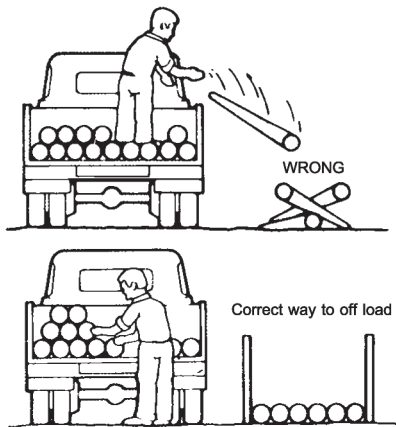

b) Where ever possible the loading and unloading of pipes should be carried out by hand. A six meter length of 10 nominal diameter PN 1 2 Watermain weighs 93 kilograms and can be carried by two men in normal site conditions.

c) If mechanical lifting equipment is used no metallic slings, hooks or chains should be used in direct contact with the pipe. Rope or web slings are preferred, which will not gouge or cut the pipe wall. Gouges and cuts in the pipe wall can affect the pressure resisting capabilities of the pipe.

d) When pipes are being handled at or near freezing conditions, they should never be dropped or conversely have objects dropped on them. The impact strength of material is high but is reduced somewhat at lower temperatures and extra care is required. Pipes and fitting which have been subjected to abuse must be thoroughly examined before use for any evidence of structural damage.

### TRANSPORT

a) If the pipe is to be transported the vehicles used should have a flat bed free from sharp projections of any kind.

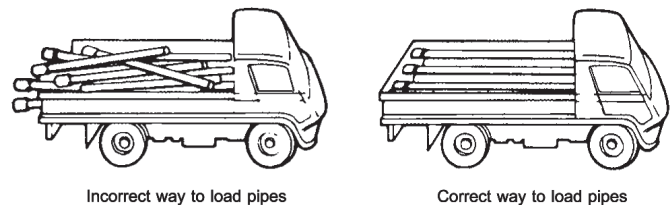

b) The pipes should be evenly supported throughout their length and should not overhang the vehicle bed by more than 1 metre. Pipe should be loaded with sockets at alternate ends.

c) Larger diameter and/or thicker walled pipes should be loaded first and the vehicle should be fitted with side supports at no greater than 1.5 m. centres or continuously supported. These supports should be free of sharp edges.

### AVERAGE WEIGHTS, PLAIN ENDED PIPE, EXCLUDING JOINTS

NOMINAL DIAMETER	PN 9 PN CLASS C kg/m	PN 12 PN CLASS D kg/m	PN 15 PN CLASS E kg/m
3/8	—	—	0.11
1/2	—	—	0.16
3/4	—	—	0.22
1	—	—	0.32
1 1/4	—	0.41	0.50
1 1/2	—	0.54	0.65
2	0.68	0.82	1.02
3	1.40	1.81	2.20
4	2.31	3.01	3.61
5	3.45	4.49	5.47
6	4.97	6.52	7.89
8	7.66	9.97	12.08
10	11.86	15.47	18.75
12	16.71	21.76	26.48
14	20.09	26.27	31.88
16	26.43	34.15	41.61
18	33.34	43.33	—
20	41.16	53.29	—
24	59.27	—	—



# WATERMAIN uPVC PRESSURE PIPE

## HANDLING, TRANSPORT AND STORAGE

### STORAGE

To ensure that deterioration of pipe and fittings does not occur during storage, it is imperative that the following recommendations are adhered to.

#### BUNDLED PIPE

a) Pipes supplied in factory made bundles should be stored on a flat surface; bundles should not be stored on top of each other. The bundles should remain undisturbed until the pipe is required and any loose pipe should be stored according to the following recommendations.

#### LOOSE PIPE

a) Watermain pipes should be stacked on a flat surface free from sharp projections, stones or other protuberances likely to cause point loading or pipe deformation.

It may be necessary to level the ground at the storage point in order that pipes may be uniformly supported throughout their length.

An alternative means of storage is to lay the pipes on stout timber bearers not less than 75mm wide, placed at not greater than 1.5 m centres along the length of the pipe.

c) Side supports should be provided in the form of stout timber posts, not less than 75 mm square, placed at not greater than 1.5m centers along the length of the pipe. The width of stacked pipes should not exceed 3 metres.

When socketed pipes are stacked, the sockets should be placed at alternate ends of the stack with the socket protruding so that pipes are evenly supported along their entire length. Pipes of different sizes or wall thicknesses, should be stored separately or where this is not possible, those with larger diameters and/or thicker walls should be placed at the bottom of the stack.

d) The height of pipe stacks should never exceed seven layers or 2 metres, maximum height.

If prolonged storage (greater than one month) or storage in areas of high temperature (above 23° C) is anticipated the stack height should never exceed 4 layers or 1 metre maximum height. Such stacks should be protected from the effects of weathering (particularly ultra violet exposure) by placing tarpaulins or similar sheets over them, securely fixed to the timber support posts, to provide protected and shaded conditions, which allow a free passage of air around the pipes.

e. Pipe fittings may be subjected to damage and/or the affects of corrosion or weathering if stored for long periods. For this reason fittings should be stored in sheltered conditions in such a way that they are protected from the effects of weathering and accidental damage.

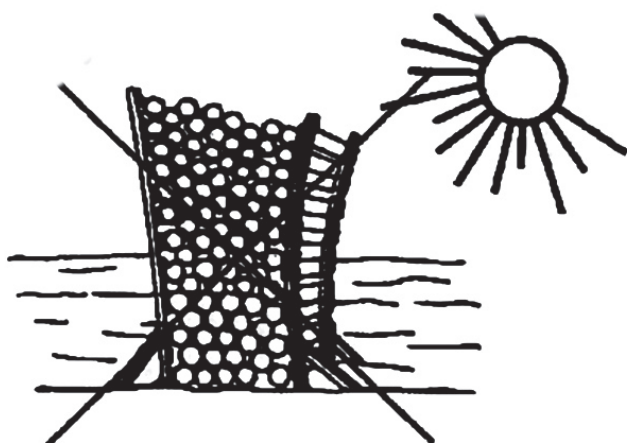

# WATERMAIN uPVC PRESSURE PIPE

## NOTES



# WATERMAIN uPVC PRESSURE PIPE

## NOTES

A series of horizontal dashed lines for taking notes.







## HEAD OFFICE

### HEPWORTH PME LLC DUBAI

P.O.Box 2345, Dubai, UAE  
Tel: +971 4 2894670  
Fax: +971 4 2894620 /1  
Email: info@corys.ae

**SALES/CUSTOMER SERVICE**  
customer.service@corys.ae

## U.A.E. OFFICES

### ABU DHABI

P.O. Box: 4894, Abu Dhabi, UAE  
Tel: +971 2 6727585  
Fax: +971 2 6783578  
Email: hpmeauh@corys.ae

### AL AIN

P.O. Box: 80862, Al Ain, UAE  
Tel: +971 3 7210727  
Fax: +971 3 7211292  
Email: hpmealn@corys.ae

## QATAR OFFICE

### DOHA

HEPWORTH PME (QATAR) W.L.L.  
P.O. Box 50207, Doha, Qatar  
Tel: +974 44506810  
Fax: +974 44506811  
Email: info@hepworthpme.com.qa

### MESAIEED

HEPWORTH PME (QATAR) W.L.L.  
P.O. Box 50207, Mesaieed, Qatar  
Tel: +974 44760588  
Fax: +974 44760525

## OMAN

CORYS PIPE INDUSTRY LLC  
P.O Box: 117, PC 113,  
Ghala Business District,  
Al Azaiba South, Muscat Governorate,  
Tel: +968 24217626/20  
Fax: +968 24210032  
Email: info.oman@corys.ae  
**CUSTOMER SERVICE**  
customer-service-oman@corys.ae

## BAHRAIN

HEPWORTH W.L.L.  
Building 1, Avenue 0010  
P.O. Box 143, Manama, Bahrain  
Tel: +973 17672050  
Fax: +973 17672583  
Email: info.bahrain@corys.ae

[www.hepworth.ae](http://www.hepworth.ae)